



INSTALLATION INSTRUCTIONS

**EBVST B-Vent
Gas Fireplaces**

ELITE™ SERIES

P/N 850025M Rev. E 01/2011

This manual is one of a set of two supporting this product.
Refer to P/N 875026M for Care and Operation Instructions.

*Ce manuel est disponible en français, simplement
en faire la demande. Numéro de la pièce 850025CF.*

MODELS

MILLIVOLT:

EBVSTNM-B
EBVPFNM-B

EBVSTPM-B
EBVPPFM-B

ELECTRONIC:

EBVSTNE-B
EBVPFNE-B



OTL Report No. 116-F-07A-5

INSTALLER: Leave this manual with the appliance.
CONSUMER: Retain this manual for future reference.
INSTALLATEUR : Laissez cette notice avec l'appareil.
CONSOMMATEUR : Conservez cette notice pour consultation ultérieure.

This appliance may be installed in an aftermarket permanently located, manufactured home (USA only) or mobile home, where not prohibited by local codes. This appliance is only for use with the type of gas indicated on the rating plate. This appliance is not convertible for use with other gases unless a certified kit is used.

WARNING / AVERTISSEMENT / AVISO

- HOT GLASS WILL CAUSE BURNS.
- DO NOT TOUCH GLASS UNTIL COOLED.
- NEVER ALLOW CHILDREN TO TOUCH GLASS.



- UNE SURFACE VITRÉE CHAUDE PEUT CAUSER DES BRÛLURES.
- LAISSER REFROIDIR LA SURFACE VITRÉE AVANT D'Y TOUCHER.
- NE PERMETTEZ JAMAIS À UN ENFANT DE TOUCHER LA SURFACE VITRÉE.

- EL VIDRIO CALIENTE CAUSARÁ QUEMADURAS.
- USTED DEBE NUNCA TOCAR EL VIDRIO CALIENTE.
- LOS NIÑOS DEBEN NUNCA TOCAR EL VIDRIO.

WARNING: If the information in these instructions is not followed exactly, a fire or explosion may result, causing property damage, personal injury, or death.

- Do not store or use gasoline or other flammable vapors and liquids in the vicinity of this or any other appliance.
- **WHAT TO DO IF YOU SMELL GAS:**
 - Do not try to light any appliance.
 - Do not touch any electrical switch; do not use any phone in your building.
 - Immediately call your gas supplier from a neighbor's phone. Follow the gas supplier's instructions.
 - If you cannot reach your gas supplier, call the fire department.
- Installation and service must be performed by a qualified installer, service agency or the gas supplier.

AVERTISSEMENT : Assurez-vous de bien suivre les instructions données dans cette notice pour réduire au minimum le risque d'incendie ou d'explosion ou pour éviter tout dommage matériel, toute blessure ou la mort.

- Ne pas entreposer ni utiliser d'essence ni d'autres vapeurs ou liquides inflammables dans le voisinage de cet appareil ou de tout autre appareil.
- **QUE FAIRE SI VOUS SENTEZ UNE ODEUR DE GAZ :**
 - Ne pas tenter d'allumer d'appareil.
 - Ne touchez à aucun interrupteur. Ne pas vous servir des téléphones se trouvant dans le bâtiment où vous trouvez.
 - Appelez immédiatement votre fournisseur de gaz depuis un voisin. Suivez les instructions du fournisseur.
 - Si vous ne pouvez rejoindre le fournisseur de gaz, appelez le service des incendies.
- L'installation et l'entretien doivent être assurés par un installateur ou un service d'entretien qualifié ou par le fournisseur de gaz.

TABLE OF CONTENTS

Packaging	Page 2
Introduction	Page 2
General Information	Page 2
Requirements for the	
Commonwealth of Massachusetts	Page 4
New York City Approval.....	Page 4
Cold Climate Insulation	Page 5
Manufactured Home Requirements ..	Page 5
Location	Page 5
Vent Termination Clearances	Page 6
Appliance and Vent Clearances	Page 7
Detailed Installation Steps.....	Page 8
Typical Installation Sequence	Page 9
Step 1. Framing.....	Page 9
Fireplace and Framing Specifications ..	Page 10
Step 2. Routing Gas Line	Page 12
Step 3. Install The Venting System ...	Page 12
Step 4. Field Wiring.....	Page 14
Step 5. Connecting Gas Line.....	Page 15
Step 6. Outside Air Kit.....	Page 16
Step 7. Verifying Appliance Operation	Page 17
Step 8. Installing Logs	Page 17
Step 9. Remove/Install Glass Door ..	Page 21
Step 10. Burner Adjustments.....	Page 21
Step 11. Hood Installation.....	Page 22
Finishing Requirements	Page 22
Step 12. Spillage Test/Safety Switch ..	Page 23
Step 13. Attaching Safety-in-	
Operation Warnings	Page 24
Gas Conversion Kits.....	Page 25

Please read and understand these instructions before beginning your installation.



We recommend that our gas hearth products be installed and serviced by professionals who are certified in the U.S. by the National Fireplace Institute® (NFI) as NFI Gas Specialists.

PACKAGING

The assembled vented gas fireplace is packaged with:

- 1 - one log set located within the firebox.
- 2 - one plastic bag containing the literature package, which consists of the care & operation manual, installation instructions, warning labels and warranty, 8 (EBVST), 4 (EBVPF) nailing flanges; plastic bag is located on top of the fireplace.
- 3 - two hoods (EBVST), or three hoods (EBVPF) taped to the top of the fireplace.
- 4 - one plastic bag of glowing embers, one plastic bag of decorative volcanic stone and one bag of vermiculate is located in the bottom compartment.

INTRODUCTION

The **Millivolt** appliances have a millivolt gas control valve with piezo ignition system. If any optional accessories that will require electrical power are to be installed, the electrical power must be provided at the time of appliance installation.

The **Electronic** appliances are designed to operate on natural or propane gas. An electronic intermittent pilot ignition system provides safe, efficient operation. External electrical power is required to operate these units.

These vented gas fireplaces are designed for residential applications. They must be installed with approved type-B, 6 in. double wall vent pipe systems routed to the outside atmosphere.

GENERAL INFORMATION

WARNING

Young children should be carefully supervised when they are in the same room as the appliance. Toddlers, young children and others may be susceptible to accidental contact burns. A physical barrier is recommended if there are at risk individuals in the house. To restrict access to a fireplace or stove, install an adjustable safety gate to keep toddlers, young children and other at risk individuals out of the room and away from hot surfaces.

AVERTISSEMENT

Les jeunes enfants devraient être surveillés étroitement lorsqu'ils se trouvent dans la même pièce que l'appareil. Les tout petits, les jeunes enfants ou les adultes peuvent subir des brûlures s'ils viennent en contact avec la surface chaude. Il est recommandé d'installer une barrière physique si des personnes à risques habitent la maison. Pour empêcher l'accès à un foyer ou à un poêle, installez une barrière de sécurité; cette mesure empêchera les tout petits, les jeunes enfants et toute autre personne à risque d'avoir accès à la pièce et aux surfaces chaudes.

Children and adults should be alerted to the hazards of high surface temperature and should stay away to avoid burns or clothing ignition.

Les enfants et les adultes devraient être informés des dangers que posent les températures de surface élevées et se tenir à distance afin d'éviter des brûlures ou que leurs vêtements ne s'enflamment.

DO NOT ATTEMPT TO ALTER OR MODIFY THE CONSTRUCTION OF THE APPLIANCE OR ITS COMPONENTS. ANY MODIFICATION OR ALTERATION MAY VOID THE WARRANTY, CERTIFICATION AND LISTINGS OF THIS UNIT.

WARNING

Improper installation, adjustment, alteration, service or maintenance can cause injury or property damage. Refer to this manual. For assistance or additional information consult a qualified installer, service agency or the gas supplier.

⚠ WARNING

Failure to comply with these installation instructions will result in an improperly installed and operating appliance, voiding its warranty. Any change to this appliance and/or its operating controls is dangerous.

⚠ WARNING

Clothing or other flammable material should not be placed on or near the appliance.

⚠ AVERTISSEMENT

On ne devrait pas placer de vêtements ni d'autres matières inflammables sur l'appareil ni à proximité.

⚠ WARNING

Any safety screen or guard removed for servicing the appliance must be replaced prior to operating the appliance.

⚠ AVERTISSEMENT

Tout écran ou protecteur retiré pour permettre l'entretien de l'appareil doit être remis en place avant de mettre l'appareil en marche.

Note: Installation and repair should be done by a qualified service person. The appliance should be inspected before use and at least annually by a professional service person. More frequent cleaning may be required due to excessive lint from carpeting, bedding material, etcetera. It is imperative that control compartments, burners and circulating air passageways of the appliance be kept clean.

Remarque: L'installation et la réparation devrait être confiées à un technicien qualifié. L'appareil devrait faire l'objet d'une inspection par un technicien professionnel avant d'être utilisé et au moins une fois l'an par la suite. Des nettoyages plus fréquents peuvent être nécessaires si les tapis, la literie, et cetera produisent une quantité importante de poussière. Il est essentiel que les compartiments abritant les commandes, les brûleurs et les conduits de circulation d'air de l'appareil soient tenus propres.

Do not use these appliances if any part has been under water. Immediately call a qualified, professional service technician to inspect the appliance and to replace any parts of the control system and any gas control which have been under water.

Ne pas utiliser cet appareil s'il a été plongé, même partiellement, dans l'eau. Appeler un technicien qualifié pour inspecter l'appareil et remplacer toute partie du système de commande et toute commande qui a été plongée dans l'eau.

⚠ WARNING

Improper installation or use of this appliance can cause serious injury or death from fire, burns, explosions or carbon monoxide poisoning.

Only trim kit(s) supplied by the manufacturer shall be used in the installation of this appliance.

Seules les trousse de garniture fournies par le fabricant doivent être utilisées pour l'installation de cet appareil.

These appliances comply with National Safety Standards and are tested and listed by OMNI-Test Laboratories, Inc. (Report No. 116-F-07A-5) to ANSI Z21.50 (in Canada, CSA-2.22), and CAN/CGA-2.17-M91 in both USA and Canada, as vented gas fireplace heaters.

Both millivolt and electronic versions of these appliances are listed by OMNI-Test Laboratories for installation in bedrooms and Manufactured Homes.

Misc. Codes / Standards -

The Installation must conform to local codes or, in the absence of local codes, with the *National Fuel Gas Code, ANSI Z223.1/NFPA 54 - latest edition* (In Canada, the current CAN/CSA-B149.1 installation code).

The appliance, when installed, must be electrically grounded and wired in accordance with local codes or, in the absence of local codes, with the *National Electrical Code, ANSI/NFPA 70 - latest edition*, or the *Canadian Electrical Code, CSA C22.1 - latest edition*.

Provide adequate clearances around air openings and adequate accessibility clearance for service and proper operation. Never obstruct the front or back openings of the appliance.

These appliances are designed to operate on natural or propane gas only. The use of other fuels or combination of fuels will degrade the performance of this system and may be dangerous.

These fireplaces are designed as supplemental heaters. Therefore, it is advisable to have an alternate primary heat source when installed in a dwelling.

Millivolt Models - The millivolt appliances are manually controlled and feature a spark igniter (piezo) that allows the appliance's pilot gas to be lit without the use of matches or batteries. This system provides continued service in the event of a power outage.

Millivolt models come standard with a manually-modulated gas valve; flame appearance and heat output can be controlled at the gas valve. The BTU Input for these appliances is shown in **Table 1**.

Electronic Models - Electronic models have a fixed rate gas valve. Input of electronic models is shown in **Table 1**.

Input (BTU) Gas Valves (all models)		
All Models	Fuel Type	Input Rate (BTU / HR)
Millivolt	Natural	37,500 high 30,000 low
Millivolt	Propane	37,500 high 30,000 low
Electronic	Natural	37,500
Electronic	Propane	37,500

Table 1

Gas Pressure - All Models

Tables 2 and 3 show the appliances' inlet and manifold gas pressure requirements:

Inlet Gas Supply Pressure (all models)		
Fuel #	Minimum	Maximum
Natural Gas	4.5" WC (1.12 kPa)	10.5" WC (2.61 kPa)
Propane	11.0" WC (2.74 kPa)	13.0" WC (3.23 kPa)

Table 2

Manifold Gas Supply Pressure (all models)		
Fuel #	Low	High
Natural Gas	(Lo) 2.2" WC (0.55 kPa)	(Hi) 3.5" WC (0.87 kPa)
Propane	(Lo) 6.3" WC (1.57 kPa)	(Hi) 10.0" WC (2.49 kPa)

Table 3

Test gauge connections are provided on the front of the millivolt and electronic gas control valve (identified IN for the inlet and OUT for the manifold side). The control valves have a 3/8" (10mm) NPT thread inlet and outlet side of the valve (refer to **Figures 1 and 2**).

Propane tanks are at pressures that will cause damage to valve components. Verify that the tanks have step down regulators to reduce the pressure to safe levels.

These appliances must be isolated from the gas supply piping system (by closing their individual manual shut-off valve) during any pressure testing of the gas supply piping system at test pressures equal to or **less than** 1/2 psig (3.5 kPa).

These appliances and their individual shut-off valves must be disconnected from the gas supply piping system during any pressure testing of that system at pressures **greater than** 1/2 psig (3.5 kPa).

These appliances must not be connected to a chimney or flue serving a separate solid fuel burning appliance.

Orifice Sizes - Sea Level to High Altitude (All Models)

These appliances are tested and approved for installation at elevations of 0-4500 feet (0-1372 meters) above sea level using the standard burner orifice sizes (marked with an "*" in **Table 4**). For elevations above 4500 feet, contact your gas supplier or qualified service technician.

Deration - At higher elevations, the amount of BTU fuel value delivered must be reduced by either:

- Using gas that has been derated by the gas company.
- By changing the burner orifice to a smaller size as regulated by the local authorities having jurisdiction and by the (USA) National Fuel Gas Code NFPA 54/ANSI Z223.1 - latest edition or, in Canada, the CAN/CSA-B149.1 codes - latest edition.

Install the appliance according to the regulations of the local authorities having jurisdiction and, in the USA, the National Fuel Gas Code NFPA 54 / ANSI Z223.1 - latest edition or, in Canada, the CAN/CSA-B149.1 - latest edition.

Flame breadth, height and width will diminish 4% for every 1,000 feet of altitude.

Burner Orifice Sizes (all models)		
Elevation Feet (meters)	Natural Gas drill size (inches)	Propane Gas drill size (inches)
0-4500 (0-1372)	#32 (0.116") * 37L82 •	#50 (0.070")* 35M90 •

Table 4

* Standard size installed at factory
• Part/Cat. Number

Gas Valve Diagrams

See **Figure 1** for Millivolt models and **Figure 2** For Electronic Models.

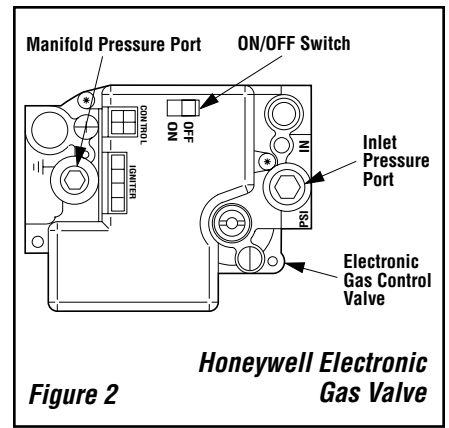
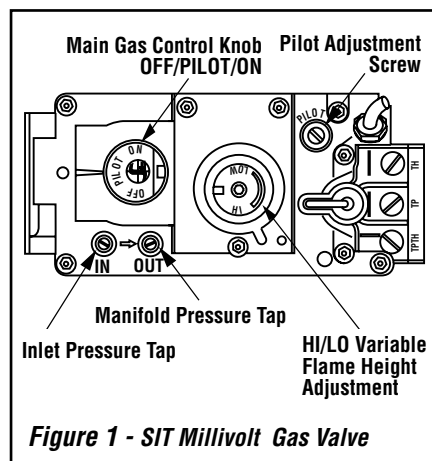

REQUIREMENTS FOR THE COMMONWEALTH OF MASSACHUSETTS

These fireplaces are approved for installation in the US state of Massachusetts if the following additional requirements are met:

- Install this appliance in accordance with Massachusetts Rules and Regulations 248 C.M.R.
- Installation and repair must be done by a plumber or gas fitter licensed in the Commonwealth of Massachusetts.
- The flexible gas line connector used shall not exceed 36 inches (92 centimeters) in length.
- The individual manual shut-off must be a T-handle type valve.

Massachusetts Horizontal Vent Requirements

In the Commonwealth of Massachusetts, horizontal terminations installed less than seven (7) feet above the finished grade must comply with the following additional requirements:

- A hard wired carbon monoxide detector with an alarm and battery back-up must be installed on the floor level where the gas fireplace is installed. The carbon monoxide detector must comply with NFPA 720, be ANSI/UL 2034 listed and be ISA certified.
- A metal or plastic identification plate must be permanently mounted to the exterior of the building at a minimum height of eight (8) feet above grade and be directly in line with the horizontal termination. The sign must read, in print size no less than one-half (1/2) inch in size, GAS VENT DIRECTLY BELOW. KEEP CLEAR OF ALL OBSTRUCTIONS.

NEW YORK CITY, NEW YORK (MEA)

Installation of these fireplaces are approved for installation in New York City in the US state of New York, if the following additional requirements are met-

- An outside air kit (FOAK-4 or FOAK-4LD) must be installed.

COLD CLIMATE INSULATION

For cold climate installations, seal all cracks around your appliance with noncombustible material and wherever cold air could enter the room. It is especially important to insulate outside chase cavity between studs and under floor on which appliance rests, if floor is above ground level. Gas line holes and other openings should be caulked or stuffed with unfaced fiberglass insulation.

If the fireplace is being installed on a cement slab in cold climates, a sheet of plywood or other raised platform can be placed underneath to prevent cold transfer to the fireplace and into the room. It also helps to sheetrock inside surfaces and tape for maximum air tightness and caulk firestops.

MANUFACTURED HOME REQUIREMENTS

This appliance may be installed in an aftermarket permanently located, manufactured home and must be installed in accordance with the manufacturer's instructions and the Manufactured Home Construction and Safety Standard, Title 24 CFR, Part 3280, in the United States, or the Standard for Installation in Mobile Homes, CAN/GSA Z240 MH Series, in Canada.

Cet appareil peut être installé comme du matériel d'origine dans une maison préfabriquée (É.U. seulement) ou mobile et doit être installé selon les instructions du fabricant et conformément à la norme Manufactured Home Constructions and Safety, Title 24 CFR, Part 3200 aux Unis ou à la norme Can/CSA-Z240 Série MM, Maisons mobiles au Canada.

This appliance is only for use with the type of gas indicated on the rating plate. This appliance is not convertible for use with other gases, unless a certified kit is used.

Cet appareil doit être utilisé uniquement avec le type de gaz indiqué sur la plaque signalétique. Cet appareil ne peut être converti à d'autres gaz, sauf si une trousse de conversion est utilisée.

CAUTION: Ensure that the cross members are not cut or weakened during installation. The structural integrity of the manufactured home floor, wall, and ceiling / roof must be maintained.

CAUTION: This appliance must be grounded to the chassis of the manufactured home in accordance with local codes or in the absence of local codes, with the National Electrical Code ANSI / NFPA 70 - latest edition or the Canadian Electrical Code CSA C22.1 - latest edition.

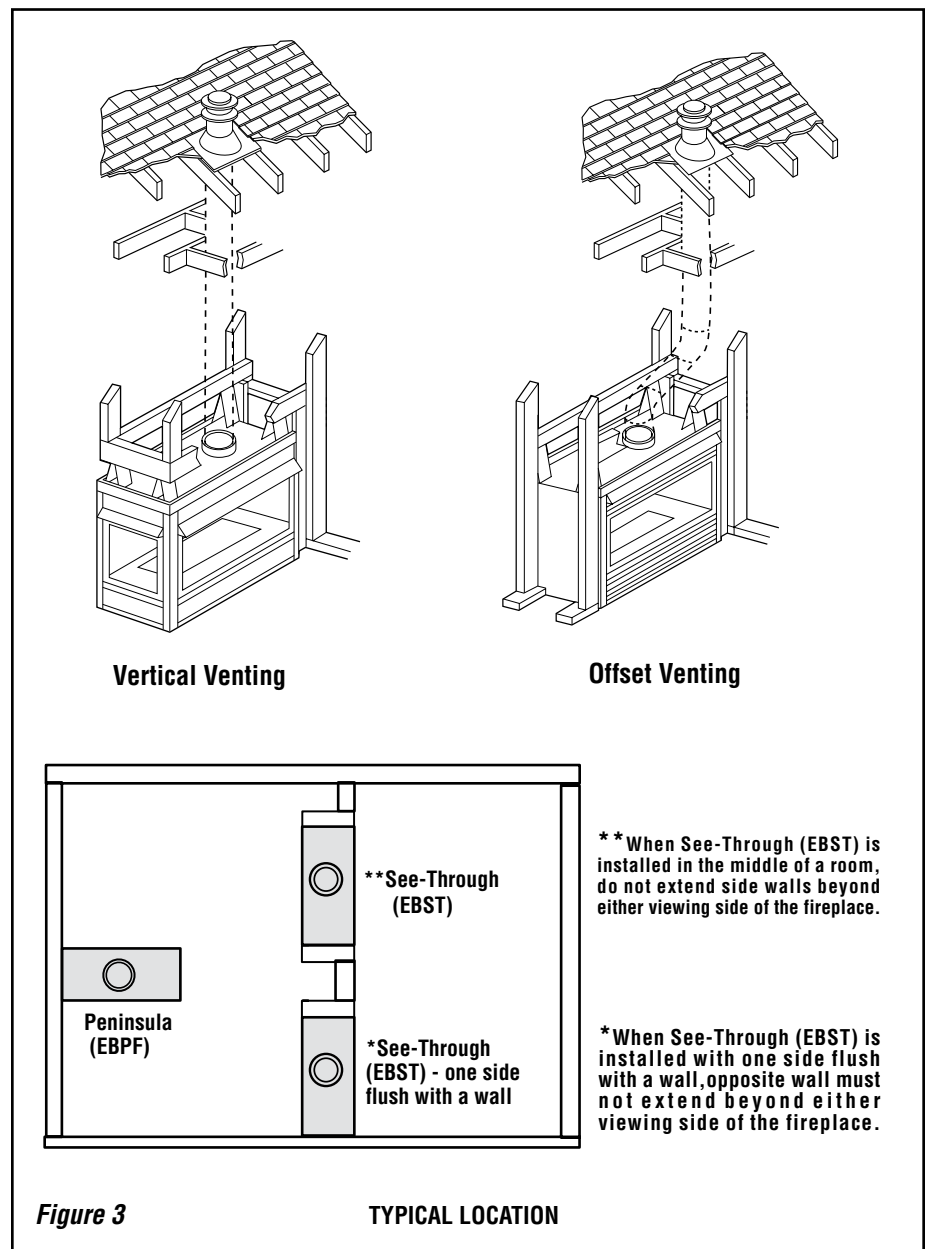

Figure 3

TYPICAL LOCATION

LOCATION

In selecting the location, the aesthetic and functional use of the appliance are primary concerns. However, vent system routing to the exterior and access to the fuel supply are also important.

Due to high temperatures, the appliance should be located out of traffic and away from furniture and draperies (Figure 3).

En raison des températures élevées, l'appareil devrait être installé dans un endroit où il y a peu de circulation et loin du mobilier et des tentures (Figure 3).

The location should also be free of electrical, plumbing or other heating/air conditioning ducting.

These appliances may be used for bedroom installations in the United States and are listed accordingly. These units may not be installed in bedrooms in Canada.

Be aware that this is a heat producing appliance. Objects placed above the unit are exposed to elevated temperatures.

VENT TERMINATION CLEARANCES

These instructions should be used as a guideline and do not supersede local codes in any way. Install venting according to local codes, these instructions, the current National Fuel Gas Code (ANSI-Z223.1) in the USA or the current standards of CAN/CSA-B149.1 in Canada.

Vertical Vent Termination Clearances

Gas Vent Rule – Gas vent caps are not permitted within 8 feet (2.4 mm) of a vertical wall or similar obstruction.

Gas vent caps that are located 8' or more from a portion of a building which extends at an angle greater than 45° upward from the horizontal may terminate in accordance with (**Figure 4**), provided that in no case shall any discharge opening on the cap be less than 2' (610 mm) horizontally from the roof surface (National Fuel Gas Code ANSI Z223.1 (NFPA 54) 7.6.2) (CAN/CGA B149).

These instructions should be used as a guideline and do not supersede local codes in any way.

Multiple Terminations – These appliances may vent adjacent to and at the same level with any other gas appliances (including direct-vent appliances) provided that there is at least 2 ft. (0.6m) between the proximal edges of the vent caps. These appliances may be vented adjacent to a chimney vent servicing a solid fuel fireplace provided the B-vent cap is at least 2 ft. (0.6m) away from the nearest point of the chimney opening.

Note: Venting terminals shall not be recessed into a wall or siding.

Vertical Vent Termination Clearances

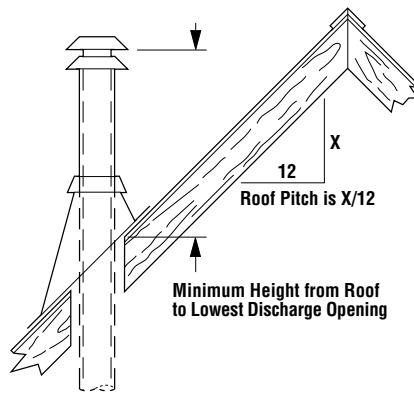

The vent / air intake termination clearances above the high side of an angled roof is as shown in the following chart:

Termination Heights For Vents Above Flat Or Sloped Roofs Ref. NFPA 54 / ANSI Z223.1		
Roof Pitch	* Feet	* Meters
Flat to 6/12	1.0	0.3
6/12 to 7/12	1.25	0.38
7/12 to 8/12	1.5	0.46
8/12 to 9/12	2.0	0.61
9/12 to 10/12	2.5	0.76
10/12 to 11/12	3.25	0.99
11/12 to 12/12	4.0	1.22
12/12 to 14/12	5.0	1.52
14/12 to 16/12	6.0	1.83
16/12 to 18/12	7.0	2.13
18/12 to 20/12	7.5	2.29
20/12 to 21/12	8.0	2.44

Figure 4

MINIMUM CLEARANCES TO COMBUSTIBLES

Appliance And Vent Clearances

The appliance is approved with zero clearance to combustible materials on all sides (as detailed in **Table 5**), with the following exception: **When the unit is installed with one side flush with a wall, the wall on the other side of the unit must not extend beyond the front edge of the unit.** In addition, when the unit is recessed, the side walls surrounding the unit must not extend beyond the front edge of the unit (see **Figure 3**).

***Note: 3 in. (75 mm) above any horizontal/inclined vent component.**

****Note: See Page 9, Step 1 and Figure 8 for clearance requirements to the nailing flange located at each side of the unit and any screw heads adjacent to it.**

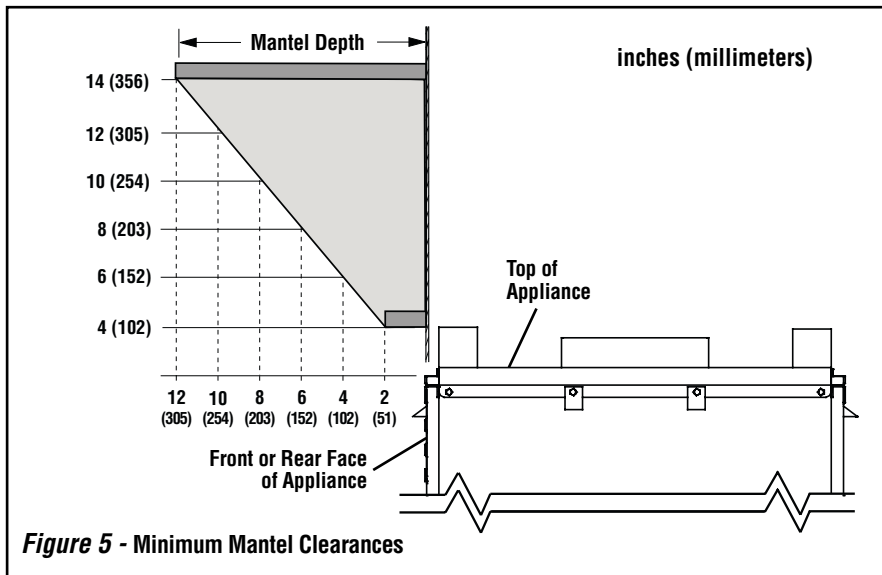

Hearth Extension - A hearth extension is not required with this appliance. If a hearth extension is used, do not block the lower control compartment door. Any hearth extension used is for appearance only and does not have to conform to standard hearth extension installation requirements.

The appliance should be mounted on a fully supported base extending the full width and depth of the unit. The appliance may be located on or near conventional construction materials. However, if installed on combustible materials, such as carpeting, vinyl tile, etc., a metal or wood barrier covering the entire bottom surface must be used.

Wall Finishes / Surrounds / Mantels

Note: Combustible wall finish materials and/or surround materials must not be allowed to encroach the area defined by the appliance front face (black sheet metal). Never allow combustible materials to be positioned in front of or overlapping the appliance face (see Figure 6 on Page 8 and Figure 32 on Page 23).

Non-combustible materials, such as surrounds and other appliance trim, may be installed on the appliance face with these exceptions: they must not cover any portion of the removable glass panel or control compartment.

Vertical installation clearances to combustible mantels vary according to the depth of the mantel. See **Figure 5**. Mantels constructed of non-combustible materials may be installed at any height above the appliance opening; however, do not allow anything to hang below the fireplace hood.

Note: We recommend the use of high temperature paint (rated 175° F or higher) on the underside of the mantel.

MINIMUM CLEARANCES* Inches (millimeters)	
Back and Sides	1/2 in. (13) 0 (0) from Spacers Or Dimples **
Top Spacers	0 (0)
Floor	0 (0)
From Bottom of Unit To Ceiling	64 (1626)
Vent	3 (76) Top* / 1 (25.4) Sides & Bottom
SERVICE CLEARANCES Feet (meters)	
Front, Back, Sides	3 feet (0.9 meters)

Table 5

DETAILED INSTALLATION STEPS

The appliance is shipped with all gas controls and components installed and pre-wired.

1 - Remove the shipping carton.

2 - Remove the top radiant panel (refer to *Figure 7*).

3 - Lift the pressure relief plates and remove the cardboard from underneath each of them.

4 - Open the control compartment access panel, by actuating the spring-loaded magnetic catches securing the panel, gently depressing the outer top corners of the panel until the catches "pop" the panel free and allowing it to swing out and down to open.

5 - Remove the bottom control compartment access panel by compressing the spring-loaded hinge pin on the left side until it disengages from the left cabinet panel hole. Pull the panel away from the fireplace.

6 - Remove the modesty panel by pulling the bottom right corner of the modesty panel out slightly to disengage the snap-fit feature; lift the modesty panel by the tab on the panel's right end, pull the right end of the panel away from the cabinet and then pull the panel diagonally out of the left side cabinet panel slots. (In the above procedure, reverse the words "left" and "right" for EDVCR models). Remove the modesty panel carefully, so that none of the wires become loose or disconnected.

7 - Open the two latches (located under the firebox floor) securing the glass enclosure panel. Remove the panel by tilting it outward at the bottom and lifting it up. Set the door aside protecting it from inadvertent damage. See *Figure 29* on page 21.

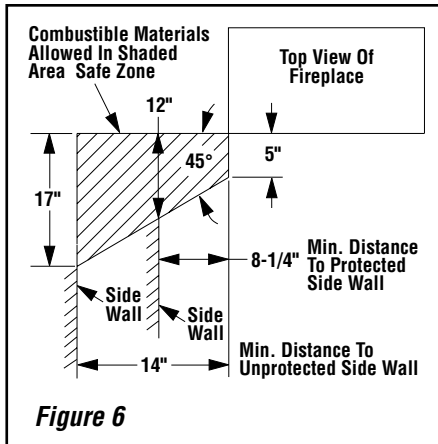

! WARNING

Failure to position the parts in accordance with these diagrams or failure to use only parts specifically approved with this appliance may result in property damage or personal injury.

! AVERTISSEMENT

Risque de dommages ou de blessures si les pièces ne sont pas installées conformément à ces schémas et ou si des pièces autres que celles spécifiquement approuvées avec cet appareil sont utilisées.

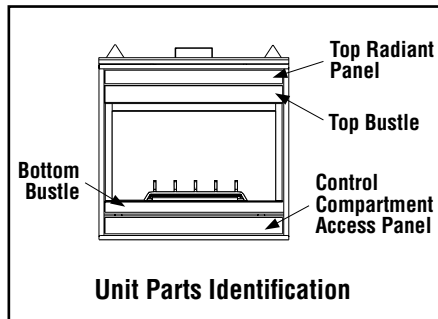

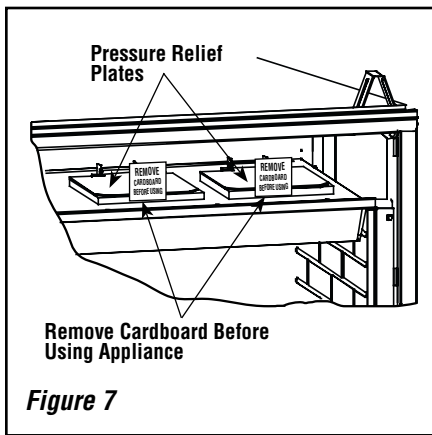

TYPICAL INSTALLATION SEQUENCE

The typical sequence of installation is outlined below. However, each installation is unique and may result in variations to the steps described.

See the page numbers references in the following steps for detailed procedures.

Step 1. (page 9) Construct the appliance framing. Position the appliance within the framing and secure with nailing brackets.

Step 2. (page 12) Route gas supply line to appliance location.

Step 3. (page 12) Install the vent system and exterior termination.

Step 4. (page 14) Field Wiring

- a. Millivolt Appliances – The operating control switch is factory installed.
- b. Electronic Appliances – Connect 120 Vac electrical power to the appliance receptacle.

Step 5. (page 15) Make connection to gas supply.

Step 6. (page 16) Install and verify outside air kit operation.

Step 7. (page 17) Checkout appliance operation.

Step 8. (page 17) Install the log set, vermiculite, lava rock and glowing embers.

Step 9. (page 21) removing and Installing glass enclosure panels.

Step 10. (page 21) Adjust burner primary air shutter to achieve proper flame appearance.

Step 11. (page 22) Install the hoods.

Step 12. (page 23) Conduct limit switch spillage test.

Step 13. (page 24) Attach safety in operation warnings.

Before proceeding it may be helpful to remove the log set form the firebox and remove the embers and volcanic stone from the control compartment. Refer to the following steps:

1. Remove the front glass enclosure panel (see *Removing and Installing Glass Enclosure Panels* on **Page 21**).

2. Remove log set box from firebox. Next, remove embers and volcanic stone from control compartment. **Handle logs carefully to prevent breakage.**

Step 1. FRAMING

Frame these appliances as illustrated in **Figures 9 (EBVST) or 10 (EBVPF)**. All framing details must allow for a minimum clearance to combustible framing members as shown in **Table 5 on page 8**. If the appliance is to be elevated above floor level, a solid continuous platform must be constructed. Headers may be in direct contact with the appliance top spacers but must not be supported by them or notched to fit around them. All construction above the appliance must be self supporting, **DO NOT** use the appliance for structural support.

Side Nailing Flanges

The fireplace should be secured to the framing at the side(s) and/or rear of the unit using the factory-provided nailing flanges. Install the nailing flanges - 8 (EBVST), 4 (EBVPF) - as shown in **Figure 8** using the existing screws.

Position the fireplace within the framing. When required, the flanges may be bent 90 degrees by hand or with the assistance of a hammer. Use wood screws to secure the nailing flanges to the framing. **See Table 5 on page 8** for clearances of framing members to cabinet parts in the nailing flange area. The nailing flange itself is exempt from these clearances.

Floor Nailing Tabs

Secure the fireplace to the floor as shown in **Figure 8**.

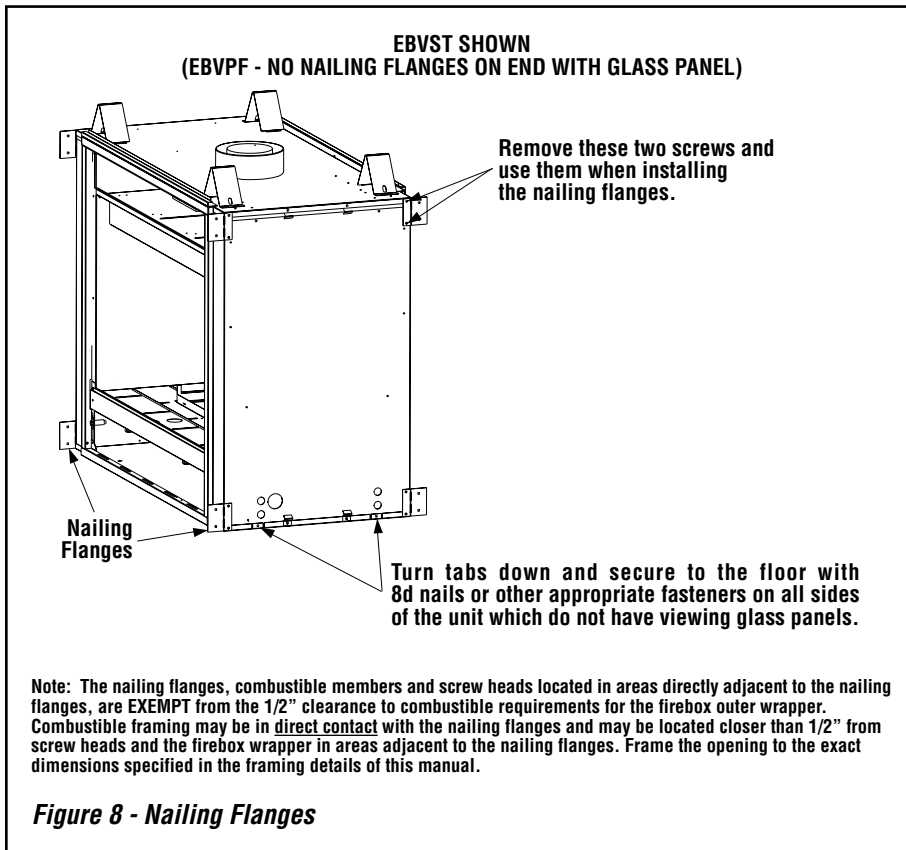

FIREPLACE FRAMING SPECIFICATIONS

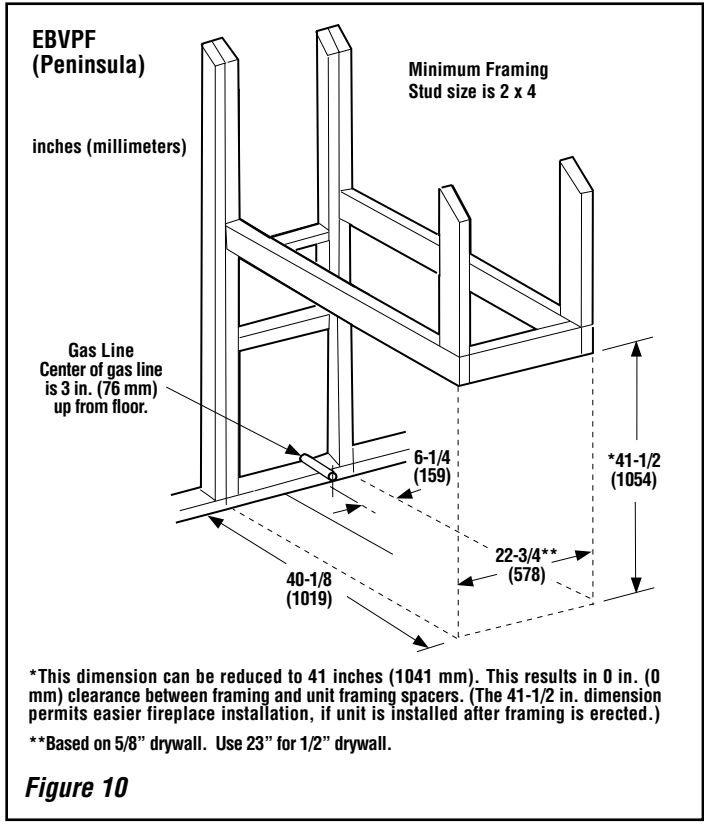
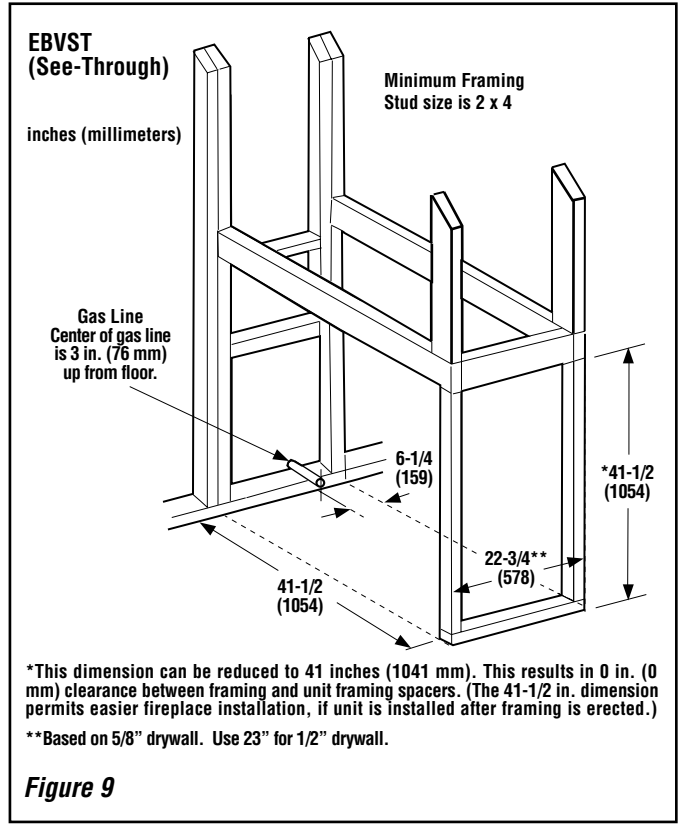

FIREPLACE SPECIFICATIONS

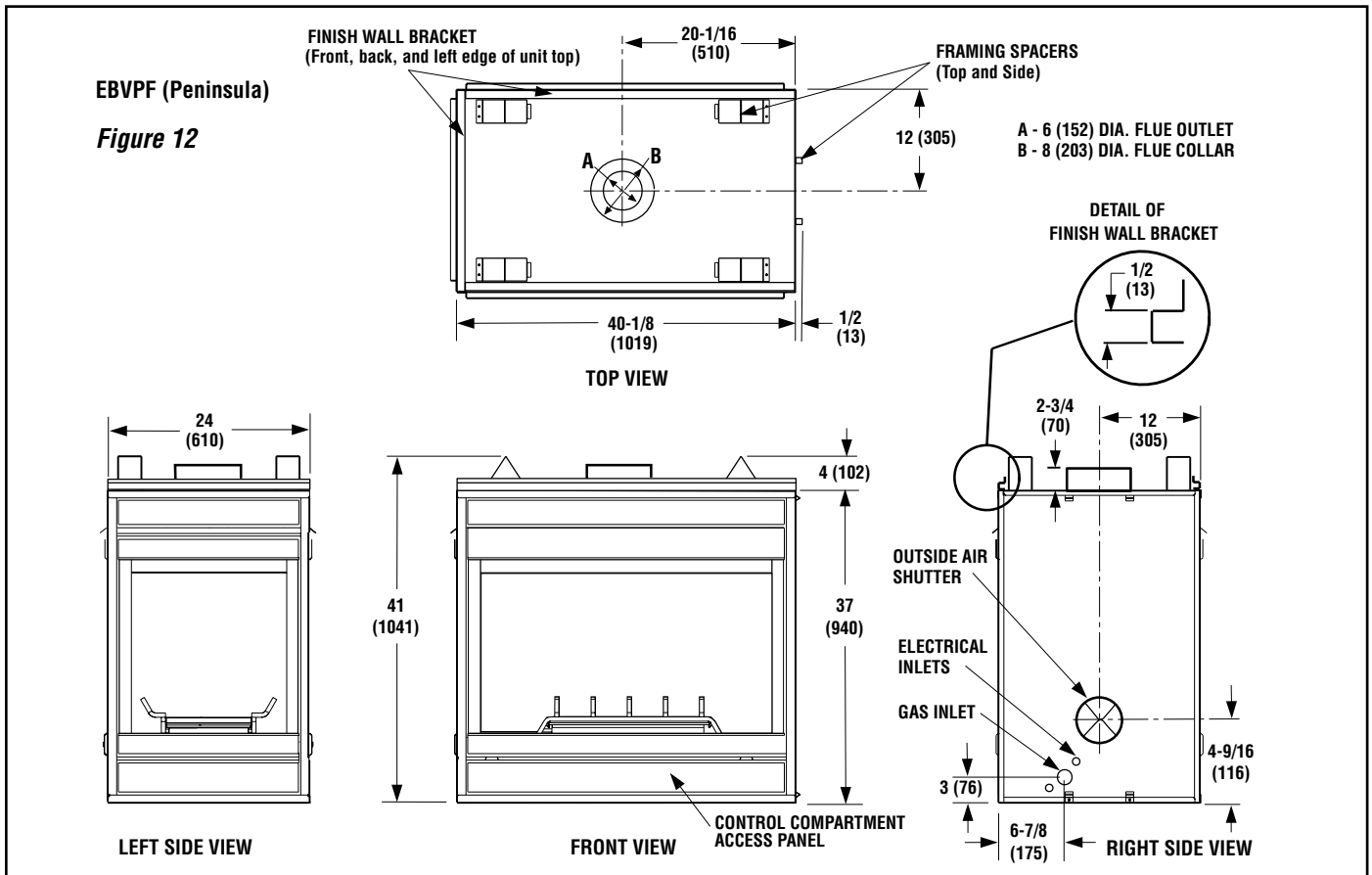
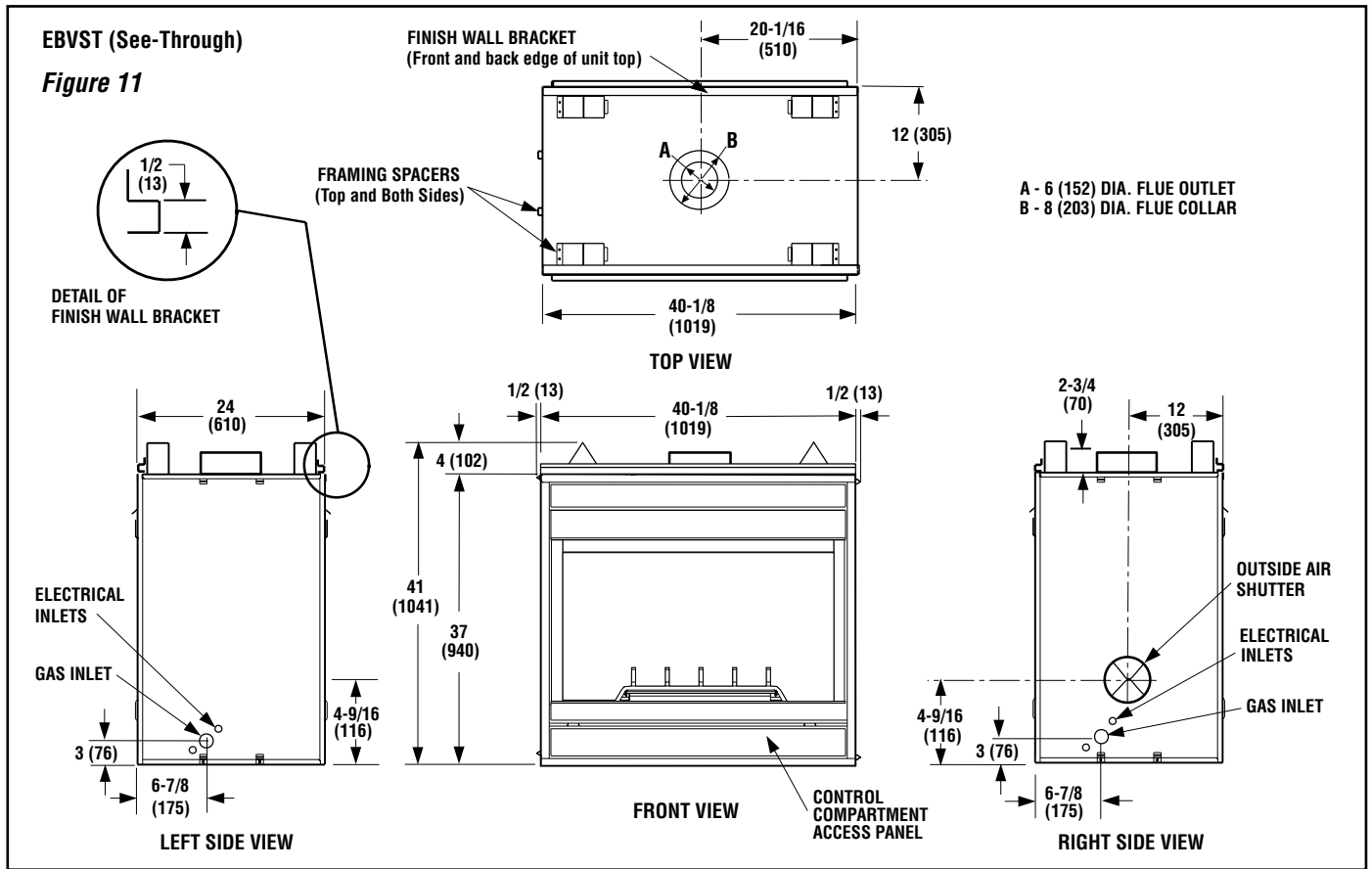

NOTE: DIAGRAMS & ILLUSTRATIONS ARE NOT TO SCALE.

Step 2. ROUTING GAS LINE

Route a 1/2" (13 mm) gas line to the left side of the appliance as shown in **Figure 13**. Gas lines must be routed, constructed and made of materials that are in strict accordance with local codes and regulations. All appliances are factory-equipped with a flexible gas line connector and 1/2 inch shutoff valve. (See **Step 5 on Page 15**).

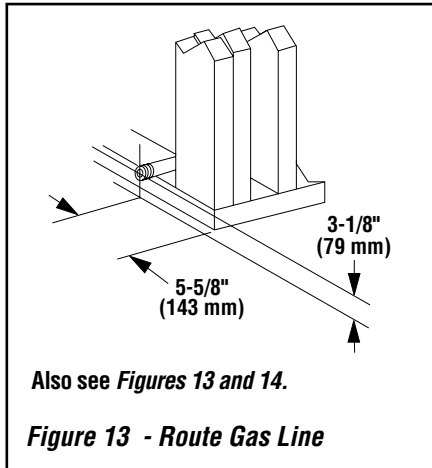

Proper Sizing of Gas Line

Properly size and route the gas supply line from the supply regulator to the area where the appliance is to be installed per requirements outlined in the National Fuel Gas Code, NFPA 54 - latest edition (USA) or CAN/CSA-B149.1 - latest edition (Canada).

Never use galvanized or plastic pipe. Refer to **Table 6** for proper sizing of the gas supply line, if black iron pipe is being used. Gas lines must be routed, constructed and made of materials that are in strict accordance with local codes and regulations. We recommend that a qualified individual such as a plumber or gas fitter be hired to correctly size and route the gas supply line to the appliance.

Installing a gas supply line from the fuel supply to the appliance involves numerous considerations of materials, protection, sizing, locations, controls, pressure, sediment, and more. Certainly no one unfamiliar and unqualified should attempt sizing or installing gas piping.

Schedule 40 Black Iron Pipe Inside Diameter (Inches)		
Schedule 40 Pipe Length (feet)	Natural Gas	Propane Gas
0-10	1/2	3/8
10-40	1/2	1/2
40-100	1/2	1/2
100-150	3/4	1/2
150-200	3/4	1/2

Table 6

Notes:

- All appliances are factory-equipped with a flexible gas line connector and 1/2 inch shutoff valve.
- See **Massachusetts Requirements on Page 4** for additional requirements for installations in the state of Massachusetts in the USA.
- The gas supply line should Not be connected to the appliance until **Step 5 (Page 15)**.
- A pipe joint compound rated for gas should be used on the threaded joints. **Ensure propane resistant compounds are used in propane applications.** Be very careful that the pipe compound does not get inside the pipe.
- It is recommended to install a sediment trap in the supply line as close as possible to the appliance. Appliances using Propane should have a sediment trap at the base of the tank.
- Check with local building official for local code requirements (i.e. are below grade penetrations of the gas line allowed?, etc).

IMPORTANT: If propane is used, be aware that if tank size is too small (i.e. under 100-lbs, if this is the only gas appliance in the dwelling. Ref. NPFA 58), there may be loss of pressure, resulting in insufficient fuel delivery (which can result in sooting, severe delayed ignition or other malfunctions). Any damage resulting from an improper installation, such as this, is not covered under the limited warranty.

Step 3. INSTALL THE VENT SYSTEM

General Information

These instructions should be used as a guideline and do not supersede local codes in any way. Install venting according to local codes, these instructions, the current National Fuel Gas Code (ANSI-Z223.1) in the USA or the current standards of CAN/CSA-B149.1 in Canada.

Ensure clearances are in accordance with local installation codes and the requirements of the gas supplier.

Dégagement conforme aux codes d'installation locaux et aux exigences du fournisseur de gaz.

These fireplaces must be vented directly to the outside.

The vent system may not service multiple appliances, and must never be connected to a flue serving a solid fuel burning appliance. The vent pipe is tested to be run inside an enclosed wall (such as a chase). There is no requirement for inspection openings in the enclosing wall at any of the joints in the vent pipe.

In the United States, vent installation must conform with local building codes. In the absence of local codes, vents must be installed in accordance with the current edition of the National Fuel Gas Code (ANSI-Z223.1).

In Canada, vent installation must conform with local building codes. In the absence of local codes, vents must be installed in accordance with the current edition of the National Standard of Canada CAN/CGA-B149.1 or B149.2 Installation Code.

This gas fireplace must be vertically vented using listed 6 in. type-B, double-walled vent pipe and a listed vent termination.

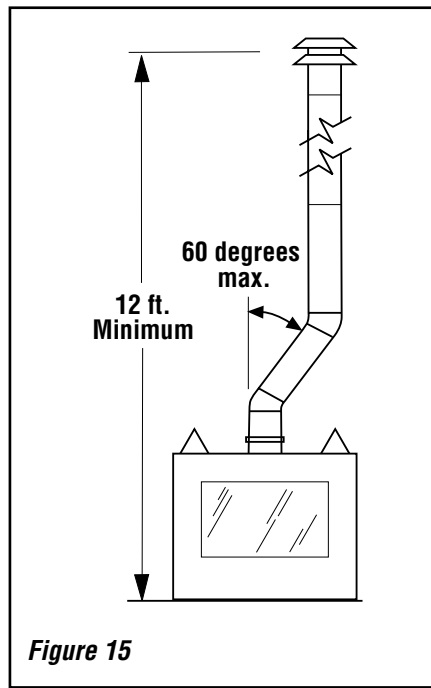
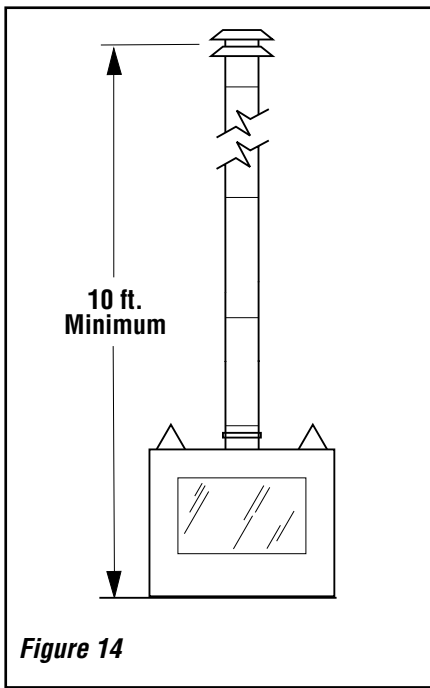

Slip the first 6 inch (152 mm) section of B-Vent over the fireplace flue outlet and secure with four sheetmetal screws (# 8 or larger), and install the remainder of the B-Vent to the outside. Minimum overall height of the vent system and appliance must be 10' (2.54 m) vertical - no offset (see **Figure 14**); or 12' (3.7 m) when an offset up to 60 degrees from the vertical is used - this offset may start at the fireplace flue collar (see **Figure 15**). **The maximum overall height of the vent system and appliance should not exceed 40 feet.**

Install the B-vent system in accordance with the vent manufacturer's instructions.

CAUTION: THIS APPLIANCE CANNOT BE VENTED HORIZONTALLY.

Note: Refer to the vent manufacturers installation instructions for variations of venting techniques. If common venting of several units is contemplated, it should be discussed with an architect and the local Building Department.

Do not place insulation materials within 1 in. of the gas vent system.

Step 4. FIELD WIRING



CAUTION

Ground supply lead must be connected to the wire attached to the green ground screw located on the outlet box. See **Figures 17 & 18**. Failure to do so will result in a potential safety hazard. The appliance must be electrically grounded in accordance with local codes or, in the absence of local codes, the National Electrical Code, ANSI/NFPA 70-latest edition. (In Canada, the current **CSA C22-1 Canadian Electrical Code**).

CAUTION: Label all wires prior to disconnection when servicing controls. Wiring errors can cause improper and dangerous operation.

ATTENTION: Au moment de l'entretien des commandes, étiquetez tous les fils avant de les débrancher. Des erreurs de câblage peuvent entraîner un fonctionnement inadéquat et dangereux.

Verify proper operation after servicing.

S'assurer que l'appareil fonctionne adéquatement une fois l'entretien terminé.

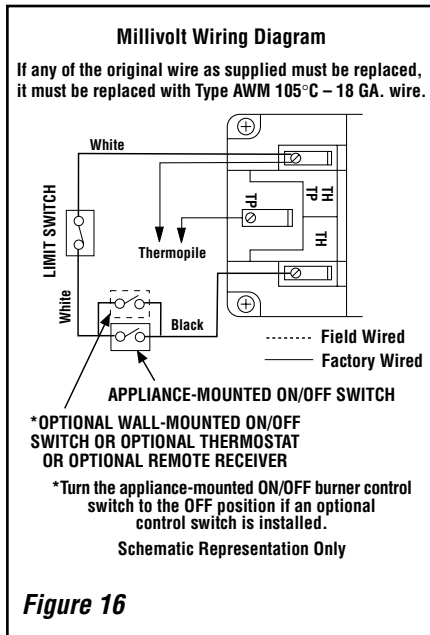

Refer to Section A for millivolt appliances and Section B for electronic appliances. The gas valve is set in place and pre-wired at the factory on both models.

A. Millivolt Wiring (See Figure 16) –

Install Optional Control Switch (OFF/ON wall switch or remote control receiver). Install snap bushing (provided in Electrical Outlet Kit) into control switch knock-out in side panel (see **Figures 11, 12 and 18**). Wire the optional control switch within the millivolt control circuit (as shown in **Figure 16**) using the 15 feet of 2 conductor wire supplied (route wires through the snap bushing to the optional control switch). Mount the optional control switch in a convenient location on a wall near the fireplace.



CAUTION

Do not connect optional control switch to 120VAC power supply.

B. Electronic Wiring (See Figure 19)

Note: The electronic appliance must be connected to the main 120 VAC power supply.

1. Locate the Electrical Outlet Kit provided (packaged in firebox - contents: junction box, 2 screws, receptacle outlet, OFF/ON rocker switch -for millivolt units only, and a snap bushing).

Note: The junction box can be installed in any of the 4 outside corners of the control compartment (outlet installed in front left corner is shown in **Figure 18**).

2. Route a 3-wire, 120 VAC, 60 Hz, 1 ph power supply to the location on appliance where junction box is to be installed.

3. Open the control compartment access panel.

4. Wire and install the outlet receptacle to junction box, then install into the chosen corner of the control compartment as shown in **Figures 16, 17 and 19**.

5. After the receptacle/junction box wiring is complete, install the field-provided metal junction box cover plate (see **Figure 18**).

6. Install the snap bushing (provided in kit) into the selected cabinet knockout opening in side cabinets (see **Figures 11, 12 and 18**). The snap bushing provides protection for the wires (see note below) passing through side cabinet going to an optional burner control switch. Wire in the burner control switch to the low voltage circuit as shown in **Figure 19**.

Note: The supplied 15 feet of 2 conductor wire has one end of each conductor connected to the gas valve circuit and the other end of each conductor placed loose on top of the appliance.

Important Note: The gas valve OFF/ON switch is shown in **Figure 22** on **Page 17**. It is integral with the gas valve and should be set to the **ON** position.



WARNING

Electronic models of these appliances are equipped with a three-prong (grounding) plug utilized in connecting the electronic components to the junction box in the lower compartment. This grounding plug provides protection against shock hazard and should be plugged directly into the properly grounded three-prong receptacle. **DO NOT** cut or remove the grounding prong from the plug.

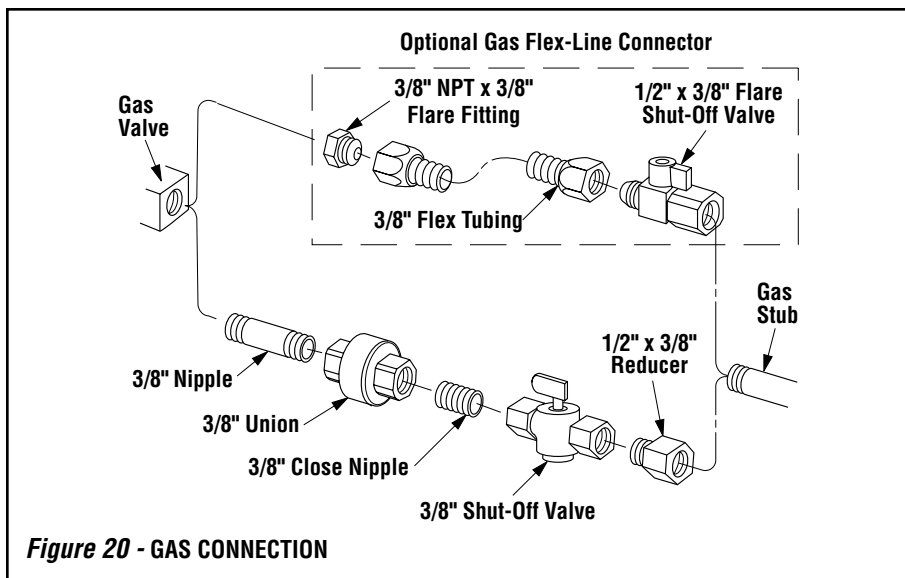

Figure 20 - GAS CONNECTION

Note: Using a soapy water solution is an effective leak test solution but it is not recommended, because the soap residue that is left on the pipes/fittings can result in corrosion over time.

- A. Light the appliance (refer to the lighting instructions label in the control compartment or in the Care and Operation Instructions manual).
- B. Brush all joints and connections with the gas leak test solution to check for leaks. If bubbles are formed, or gas odor is detected, turn the gas control knob (off/pilot/on) to the "OFF" position. Either tighten or refasten the leaking connection, then retest as described above.
- C. When the gas lines are tested and leak free, be sure to rinse off the leak testing solution.

Step 6. OUTSIDE AIR KITS

Optional outside make-up air kits, Model FOAK-4 or FAOK-4LD, may be used with these appliances. Refer to the installation instructions packaged with the air kits for specific installation information. If used, the outside air kit must be installed before the fireplace is framed and enclosed in the finished wall.

Outside air drawn into the fireplace supplies air to the fire for combustion. Only one outside air duct is necessary, if installed. See the **Figures 11 and 12** for the location of the units outside air inlet.

If additional length of duct is necessary, purchase locally available U.L. Class 0 or Class 1 metallic ducting. The duct may extend up to 50' (15.24 m) in any direction.

Note: When installing the air duct vertically, **DO NOT** terminate the duct closer than 3' below the chimney top.

Outside combustion air ducting may be run upwards or vertically through framing and ceiling joists, with the hood installed through an outside wall and 3' (1 m) below the termination. Ducting may also be run downward through floor Joists and under the home to a ventilated crawlspace not considered part of the living area of the home.

Note: Do not terminate outside air kit in attic space under any circumstances.

CAUTION: NEVER LOCATE INLET WHERE IT CAN BE BLOCKED BY SHRUBS, SNOW DRIFTS, ETC. NEVER LOCATE INLET IN GARAGE OR ANY AREA WHERE THERE IS ANOTHER FUEL BURNING APPLIANCE OR PRODUCTS EMITTING COMBUSTIBLE GASES SUCH AS PAINT, GASOLINE, ETC. IN COLD CLIMATES, IT IS RECOMMENDED THE COMBUSTION AIR DUCT BE INSULATED.

After completing the installation of the optional outside air vent system, the outside air control lever must be put in service and tested to ensure proper operation before completing any enclosure around the firebox. Failure to do so may result in extensive and costly rework.

Before the operation of the vent system can be tested, the lever securing screw must be removed. See **Figure 21**.

The hand operated outside air control lever is located on the right side of the fireplace opening. See **Figure 21**.

To open the outside air shutter, open the bottom control access panel, reach into the gap between the firebox bottom and the modesty panel, and pull the outside air control lever all the way out.

The outside air shutter should be fully open when the fireplace is in use and completely closed when the fireplace is not being used. Closing it when not in use will prevent outside cold air from entering the dwelling.

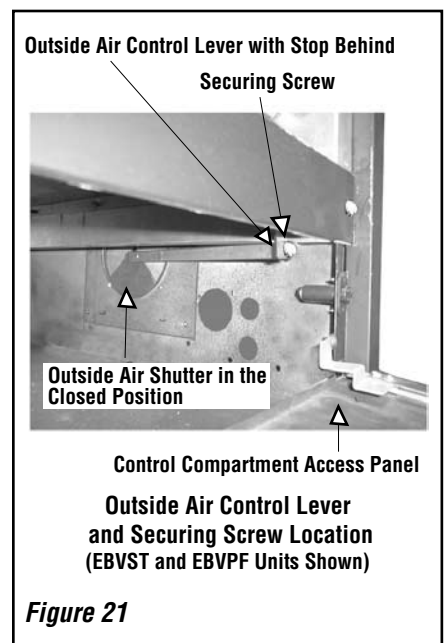

Figure 21

Operate the actuator through several cycles including the closed position. Ensuring proper operation and freedom of movement. Return the actuator arm to the closed position.

Step 7. VERIFYING APPLIANCE OPERATION

Turn on burner and observe the individual tongues of flame on the burner. Make sure all ports are open and producing flame evenly across the burner. If any ports are blocked, or partially blocked, clean out the ports.

With gas line installed run initial system checkout before closing up the front of the unit. Follow the pilot lighting instructions provided in the Care and Operation Instructions manual. For piezo igniter location see **Figure 22** (millivolt appliances only).

Note: Lighting Instructions are also found on the literature tag tied to the gas piping next to the gas valve. To access the tag, open the lower control compartment door (**Figure 22**) by pushing in simultaneously the left and right top corners of the door. (The door is hinged at the bottom). Remove the bottom compartment door by sliding the hinge pin, located at the door's left side, to the right until it disengages from the left corner post hole. Remove the modesty panel. To remove the modesty panel, slide the panel forward until it contacts the cabinet bottom panel, then lift straight up and tilt forward. Remove the modesty panel carefully, so that none of the wires become loose or disconnected.

When first lighting the appliance, it will take a few minutes for the line to purge itself of air. Once purging is complete, the pilot and burner will light and operate as indicated in the instruction manual.

Subsequent lighting of the appliance will not require such purging. Inspect the pilot flame (remove logs, if necessary, handling carefully).

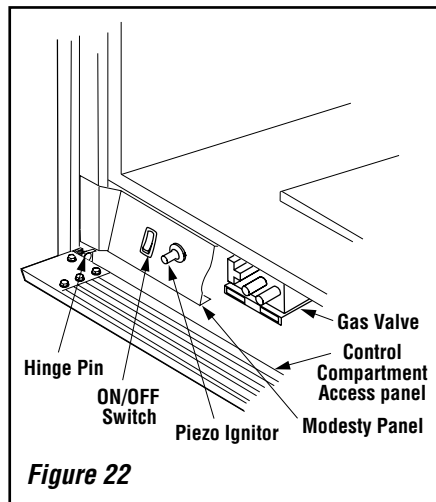

Figure 22

Millivolt Appliance Checkout

The pilot flame should be steady, not lifting or floating. Flame should be blue in color with traces of orange at the outer edge.

The top 3/8" (10 mm) at the pilot generator (thermopile) and the top 1/8" minimum (tip) of the quick drop out thermocouple should be engulfed in the pilot flame.

The flame should project 1" (25 mm) beyond the hood at all three ports (see **Figure 23**). Replace logs if removed for pilot inspection.

To light the burner; turn "ON" the remote wall switch and rotate the gas valve control knob counterclockwise to the "ON" position ("ON" will be at the top side of the valve).

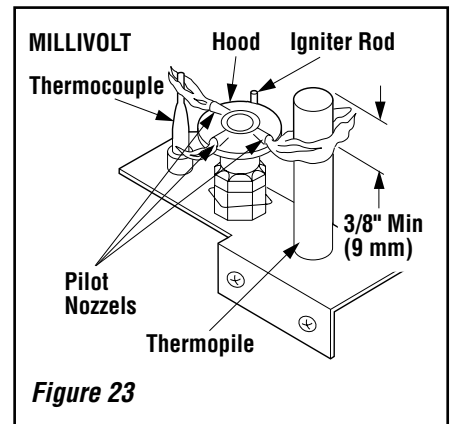

Figure 23

Electronic Appliance Checkout

To light the burner, turn 'ON' the unit mounted On/Off switch or the optional remote wall switch. Ensure the igniter lights the pilot. The pilot flame should engulf the flame rod as shown in **Figure 24**.

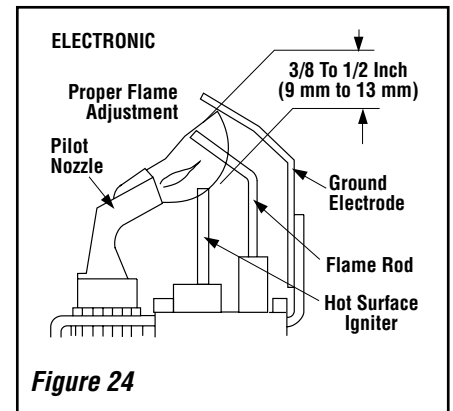

Figure 24

Step 8. INSTALL VERMICULITE, GLOWING EMBERS AND LOGS

NOTE: Turn off all electricity to the appliance before you install vermiculite, embers and logs. DO NOT attempt to install the logs until the appliance installation has been completed, the gas line connected and tested for leaks and the initial burner operation has been checked out.

INSTALLATION STEPS:

READ WARNINGS ON THIS PAGE BEFORE PROCEEDING. FOLLOW THE LOG PLACEMENT INSTRUCTIONS EXACTLY

1. **Remove the front glass enclosure panel** (see *Glass Enclosure Panel Removal and Installation Instructions, Page 21*).
2. **Remove the following from firebox**, log set, bag of embers and bag of vermiculite. **Handle logs carefully to prevent breakage.**
3. **Ensure the Grate is properly installed** in the firebox with the 4 legs of the grate fitting into the 4 dimples on the firebox floor.
4. **Placement of Glowing Embers -**
Separate the Embers (rockwool) into pieces about the size of a quarter (see *Figure 25*). Keep the pieces fluffed up, not matted. Distribute these pieces over the surface of the burner, as shown in *Figure 26*. Do not use more than is necessary. Ensure that the main burner ports remain uncovered by the ember material.
5. **Place Lava Rock -** Spread lava rock evenly over firebox floor.
6. **Install Vermiculite -** Place some vermiculite on the firebox floor around the grate (the entire bag of vermiculite will NOT be used). See *Figure 26*. **DO NOT PLACE ANY VERMICULITE ON THE BURNER.**

Note: This appliance is provided with enough Glowing Embers for several applications, do not use all that is in a new bag at one time. For best glowing effect, replace the ember material annually. Replacement Glowing Embers are available (order Catalog Number 88L53).

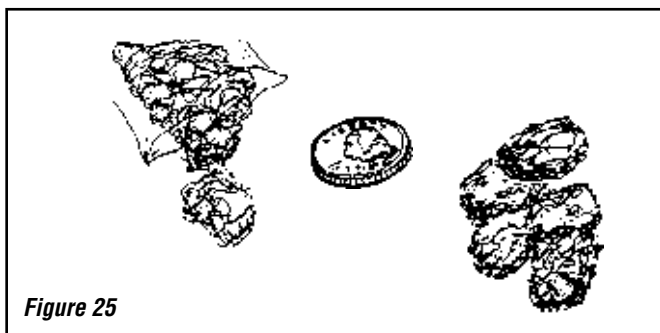

Figure 25

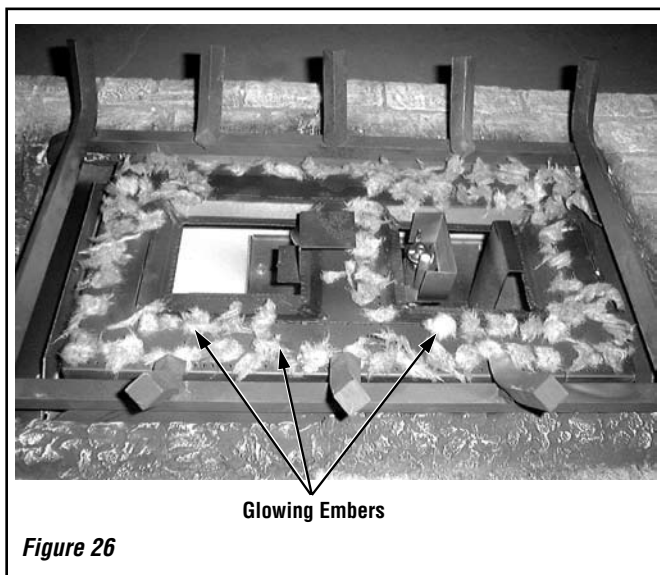

Figure 26

REFERENCE Firebox Accessories / Parts		
Cat. No.	Model No.	Description
88L53	FGE	Bag of Glowing Embers
80L42	FDVS	Bag of Decorative Volcanic Stone

WARNING

- **DO NOT attempt to install the logs until the appliance installation has been completed, the gas line connected and tested for leaks and the initial burner operation has been checked out.**
- **The size and position of the log set was engineered to give the appliance a safe, reliable and attractive flame pattern. Any attempt to use a different log set in the fireplace will void the warranty and will result in incomplete combustion, sooting, and poor flame quality.**
- **Logs get very hot and will remain hot up to one hour after gas supply is turned off. Handle only when logs are cool. Turn off all electricity to the appliance before you install grate, volcanic stone, vermiculite, embers and logs.**
- **This appliance is not designed to burn wood. Any attempt to do so could cause irreparable damage to the appliance and prove hazardous to your safety.**
- **If logs are not installed according to the log installation instructions, flame impingement and improper combustion could occur and result in soot and/or excessive production of carbon monoxide (CO), a colorless, odorless, toxic gas.**

EBVPF AND EBVST LOG PLACEMENT

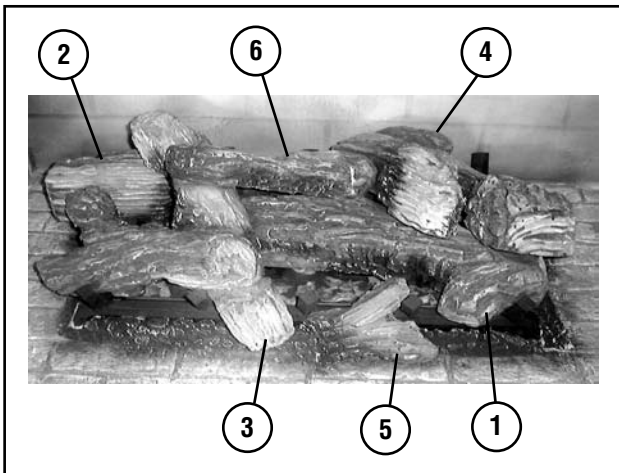

Log Number	Description	Part Number
1	Log, Corner	55M18
2	Log, Rear/Left	55M19
3	Log, Front/Left	55M20
4	Log, Rear/Right	55M21
5	Log, Front/Center	55M22
6	Log, Center/Top	55M23

Catalog Number for the entire log set: 55M04

STEP 1

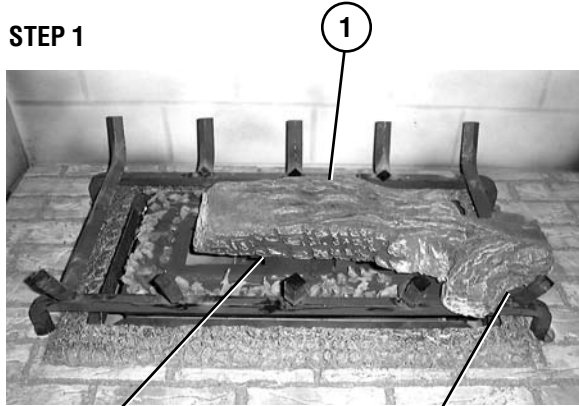

Position Groove At The Bottom Of Log (1) Over The Burner Log Support Bracket

Position The Groove At The Bottom Of Log (1) Over The Grate And Slide It Forward Against The Grate Here

STEP 2

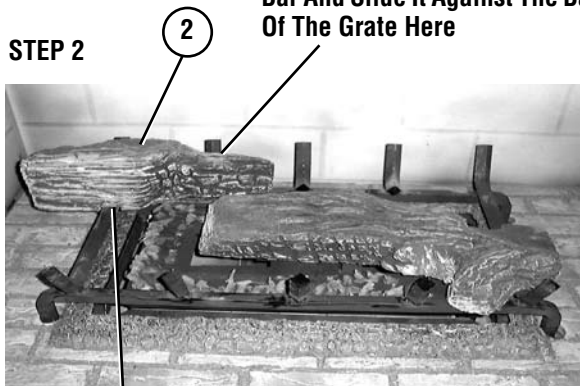

Position Groove At The Bottom Of Log (2) Over The Grate Here And Slide It Against The Back Of The Grate

Position Log (2) Over The Grate Bar And Slide It Against The Back Of The Grate Here

STEP 3

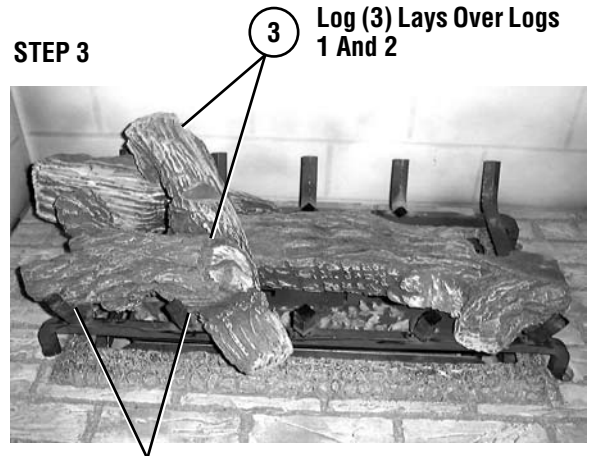

Place Bottom Hole Of Log (3) On Pin In Log (2). Position Grooves At The Bottom Of Log (3) Over The Grate.

STEP 4

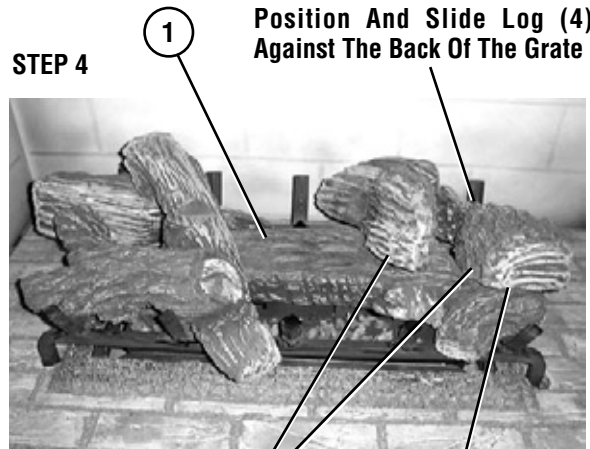

Place Log (4) Over The Flat Spot On Log (1) Here

Position And Slide Log (4) Against The Back Of The Grate

Figure 27

EBVPF AND EBVST LOG PLACEMENT (CONTINUED)

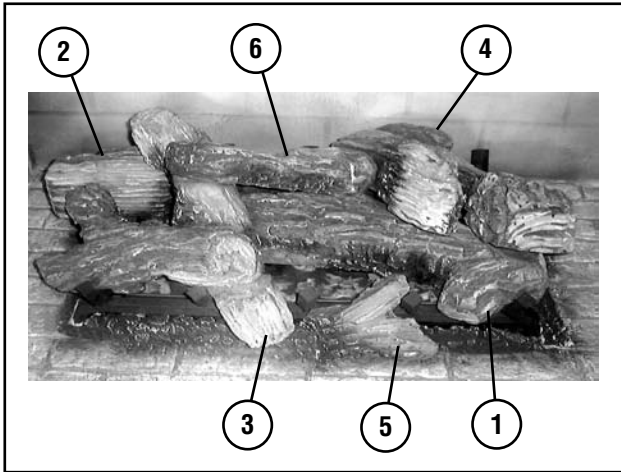

Log Number	Description	Part Number
1	Log, Corner	55M18
2	Log, Rear/Left	55M19
3	Log, Front/Left	55M20
4	Log, Rear/Right	55M21
5	Log, Front/Center	55M22
6	Log, Center/Top	55M23

Catalog Number for the entire log set: 55M04

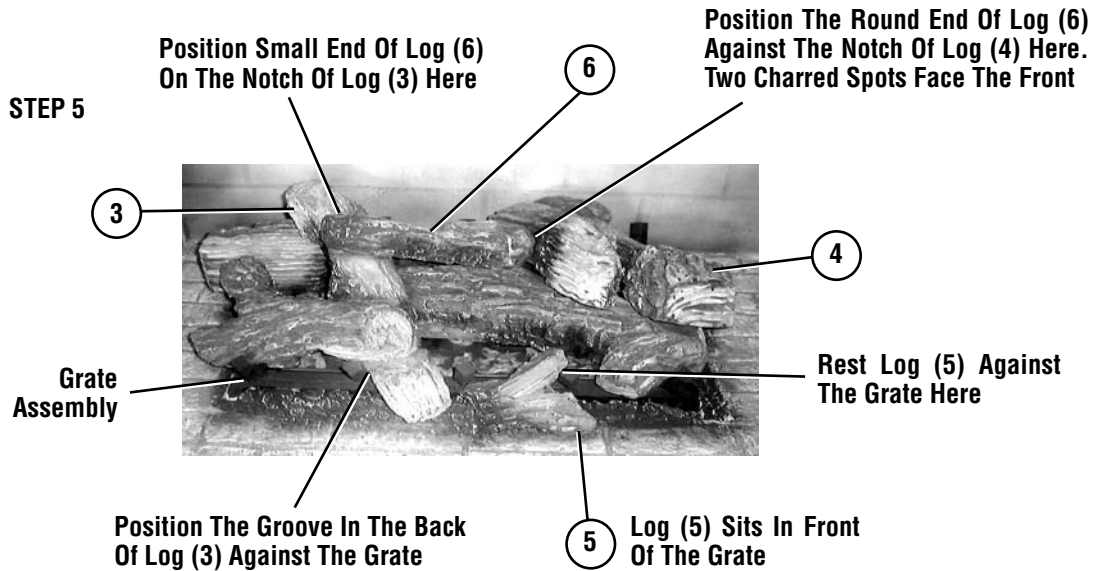

Figure 28

Step 9. REMOVING AND INSTALLING THE GLASS DOOR

! WARNING

- Do not attempt to substitute the materials used on these doors, or replace cracked or broken glass.
- Handle this glass with extreme care! Glass is susceptible to damage – Do not scratch or handle roughly while reinstalling the glass door frame.
- The glass door(s) of this appliance must only be replaced as a complete unit as provided by the manufacturer. Do not attempt to replace broken, cracked or chipped glass separately.
- Do not attempt to touch the front enclosure glass with your hands while the fireplace is in use.

! WARNING

Do not operate appliance with the glass front removed, cracked or broken.

! AVERTISSEMENT

Ne pas utiliser l'appareil si le panneau frontal en verre n'est pas en place, est craqué ou brisé.

Only doors certified with the appliance shall be used.

Seules des portes certifiées pour cet appareil doivent être utilisées.

CAUTION: DO NOT abuse glass door by striking or slamming shut.

Removing Glass Enclosure Panel (see Figure 29)

Remove the top louver assembly or radiant panel.

To access the glass door securing latches, first open the lower control compartment door (Figure 29) by pushing in simultaneously the left and right top corners of the door (the door is hinged at the bottom).

Remove the bottom compartment door by sliding the hinge pin, located at the door's left side, to the right until it disengages from the left corner post hole. Pull the door diagonally to the left, away from the fireplace.

Locate the two (2) latches at the top of the control compartment and disengage them from the door frame bottom vee-flange, pulling down on their handles to open them.

Installing Glass Enclosure Panel (see Figure 29)

Retrieve the glass door. Visually inspect the gasket on the backside of the frame. Gasket surface must be clean, free of irregularities and seated firmly.

Position the door in front of the firebox opening with the bottom of the door held away from the fireplace (Figure 29). Hook the top flange of the door frame over the top of the firebox frame.

Let the bottom of the door frame swing gently in towards the fireplace ensuring that the gasket seats evenly as the door frame draws shut. Fasten the two latches located underneath the firebox floor to the door's vee-flange. Close both the latches securely.

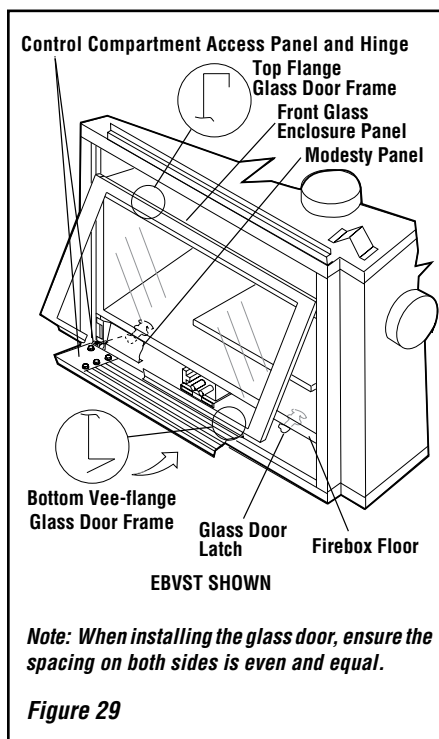

NOTE: DIAGRAMS & ILLUSTRATIONS ARE NOT TO SCALE.

Step 10. BURNER ADJUSTMENTS

Flame Appearance and sooting

Proper flame appearance is a flame which is blue at the base and becomes yellowish-orange in the body of the flame.

When the appliance is first lit, the entire flame may be blue and will gradually turn yellowish-orange during the first 15 minutes of operation. If the flame remains blue, or if the flame is orange with evidence of sooting (black tip), the air shutter opening may need to be adjusted.

If the air shutter opening is closed too far, sooting may develop. Sooting is indicated by black puffs developing at the tips of very long orange flames. Sooting results in black deposits forming on the logs, appliance inside surfaces and on exterior surfaces adjacent to the vent termination.

Sooting is caused by incomplete combustion in the flames and lack of combustion air entering the air shutter opening. To achieve a warm yellowish-orange flame with an orange body that does not soot, the shutter opening must be adjusted between these two extremes.

Air Shutter Adjustment Guidelines

- If there is smoke or soot present, first check the log set positioning to ensure that the flames are not impinging on any of the logs. If the log set is properly positioned and a sooting condition still exists, then the air shutter opening should be increased.
- The more offsets in the vent system, the larger the air shutter opening will need to be.
- An appliance operated with the air shutter opened too far, may have flames that appear blue and transparent. These weak, blue and transparent flames are termed anemic.
- Propane models may exhibit flames which candle or appear stringy. If this is present and persists, adjust the air shutter to a more closed position, then operate the appliance for a few more minutes to ensure that the flame normalizes and the flames do not appear sooty.

The following chart is provided to aid you in achieving the correct air shutter adjustment for your installation.

Air Shutter Adjustment Guidelines:		
Amount of Primary Air	Flame Color	Air Shutter Adjustment
If air shutter is closed too far →	Flame will be orange →	Air shutter gap should be increased
If air shutter is open too far →	Flame will be blue →	Air shutter gap should be decreased

⚠️ WARNINGS

- Air shutter adjustment should only be performed by a qualified professional service technician.
- Ensure front glass panel are in place and sealed during adjustment.

⚠️ CAUTIONS

- Soot will be produced if the air shutter is closed too much. Any damage due to sooting, resulting from improperly setting the air shutter, is not covered under the warranty.
- The air shutter door and nearby appliance surfaces are hot. Exercise caution to avoid injury while adjusting flame appearance.

1. Refer to **Figure 30** for proper flame appearance. To adjust the flame, rotate the adjustment rod toward the back or toward the front of the fireplace (rod located in the lower control area). Position the air shutter to the factory setting as shown in the table in **Figure 31**.
2. Light appliance (follow lighting procedure on lighting label in control compartment or see the Care and Operation Manual).
3. Allow the burner to operate for at least 15 minutes while observing the flame continuously to ensure that the proper flame appearance has been achieved. If the following conditions are present, adjust accordingly.
 - If flame appears weak or sooty, adjust the air shutter, incrementally, to a more open position until the proper flame appearance is achieved.
 - If flame remains blue, adjust the air shutter, incrementally, to a more closed position until the proper flame appearance is achieved.
4. Leave the control knob (off/pilot/on) in the ON position and the burner OFF/ON switch OFF (and remote switches, if applicable).

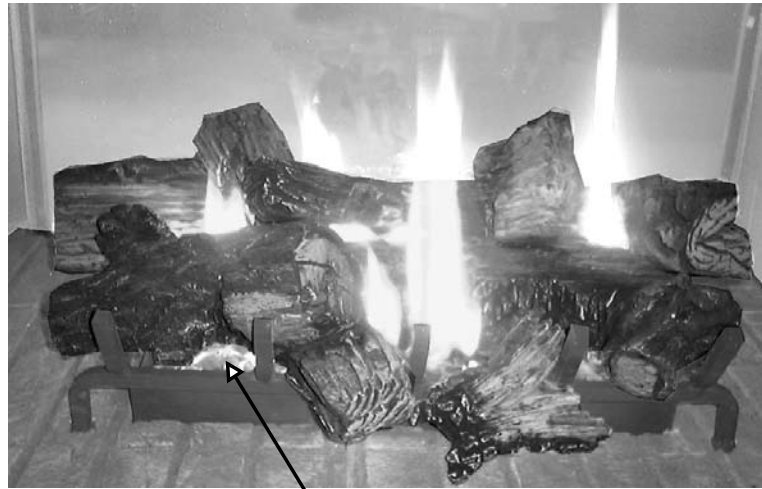

Glowing Embers (Rockwool)

Figure 30 - Burner Flame Appearance

5. When satisfied that the burner flame appearance is normal, re-install the lower control compartment door then proceed to finish the installation.

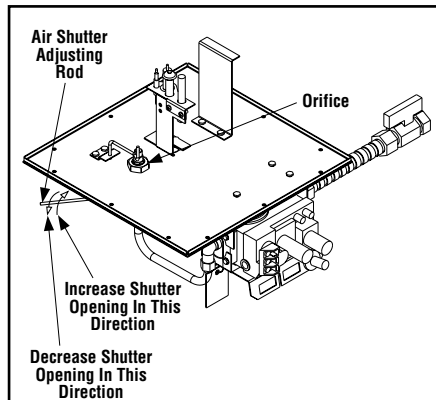

Note - Burners are omitted in this view for clarity.

MAIN BURNER FACTORY SHUTTER SETTING		
Models	Natural Gas inches (mm)	Propane Gas inches (mm)
EBVST EBVPF	1/16 (1.5)	7/16 (11)

Adjustment Rod Positions (when viewed from above)

Figure 31

Step 11. HOOD INSTALLATION

Refer to **Figure 32**. All of these appliances must have hoods installed prior to operating.

On all clean face units, slide the hoods into the slots on the lower edges of the radiant panels (**Figure 32**).

FINISHING REQUIREMENTS

- Wall Details

Complete finished interior wall. To install the appliance facing flush with the finished wall, position framework to accommodate the thickness of the finished wall (**Figure 32**).

**See Page 5 for
Cold Climate Insulation and
Page 7 for Clearances**

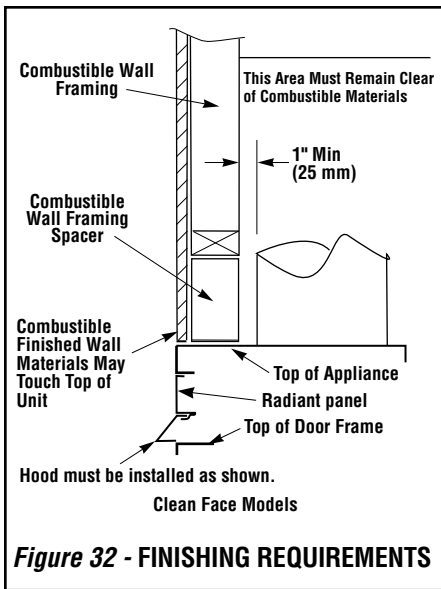

Figure 32 - FINISHING REQUIREMENTS

Step 12. Spillage Test and Safety Limit Switch Operation

Spillage Test

After appliance installation, perform this spillage test to verify that proper venting conditions exist:

- 1 - Place unit in its normally-operated condition, that is, with the glass enclosure panels in place.
- 2 - Close all doors and windows in the room. Turn on all exhaust fans in the house.
- 3 - Light the appliance.
- 4 - Wait 15 minutes.
- 5 - To check for venting action, start by holding a smoke producing device within an inch of one edge (side edge, not top or bottom edge) of one glass enclosure panel. The smoke should be drawn toward the edge of the glass enclosure panel. Continue the test by moving the smoke producing device along the entire length of both side-edges of the glass door. Repeat the test for all glass enclosure panels.
- 6 - **If the smoke is not drawn towards the edges of the glass door turn off the appliance and call a qualified service technician.**

Manually-Reset Safety Limit Switch

This appliance is equipped with a manually-reset blocked flue safety limit switch. Refer to **Figure 33** for its location. If, during appliance operation, the flame goes out (independently of the burner on/off wall switch), it may be due to the operation of this safety limit switch. **First allow the appliance to cool**, then reset the safety switch by pushing the red reset button on the back of the switch.

To access the blocked flue safety limit switch refer to *Figure 33*:

A - To access the blocked flue safety switch when top radiant panel is **not covered** with non-combustible material:

- 1 - Lift up and remove top radiant panel/eyebrow assembly on the control side of unit.
- 2 - Reach between the cabinet side and the firebox side wall and locate the blocked flue safety switch.
- 3 - Push the red reset button on the switch.

The appliance should then relight and remain lit. If this does not occur, **turn off the appliance and call a qualified service technician.**

B - To access the blocked flue safety switch when top radiant panel is **covered** with non-combustible material:

NOTE - This procedure should only be performed by a qualified service technician. **Important - Turn electrical power off before beginning this procedure.**

- 1 - Lower bottom hinged panel on the control side of the fireplace. Remove the modesty panel and glass enclosure panel as described on **page 8, Steps 4, 5, 6 and 7** under "Detailed Installation Steps" heading.
- 2 - Remove the side baffle securing screws (5) and then remove the baffle.
- 3 - Remove the safety switch bracket securing screws (2), and pull the switch/bracket assembly through the side panel slot.
- 4 - Push the red reset button on the switch.
- 5 - Reinstall the switch/bracket assembly.
- 6 - Reinstall the side baffle.
- 7 - Reinstall front glass door.
- 8 - Raise the bottom hinged panel.

The appliance should then relight and remain lit. If this does not occur, check unit for a blocked flue condition.

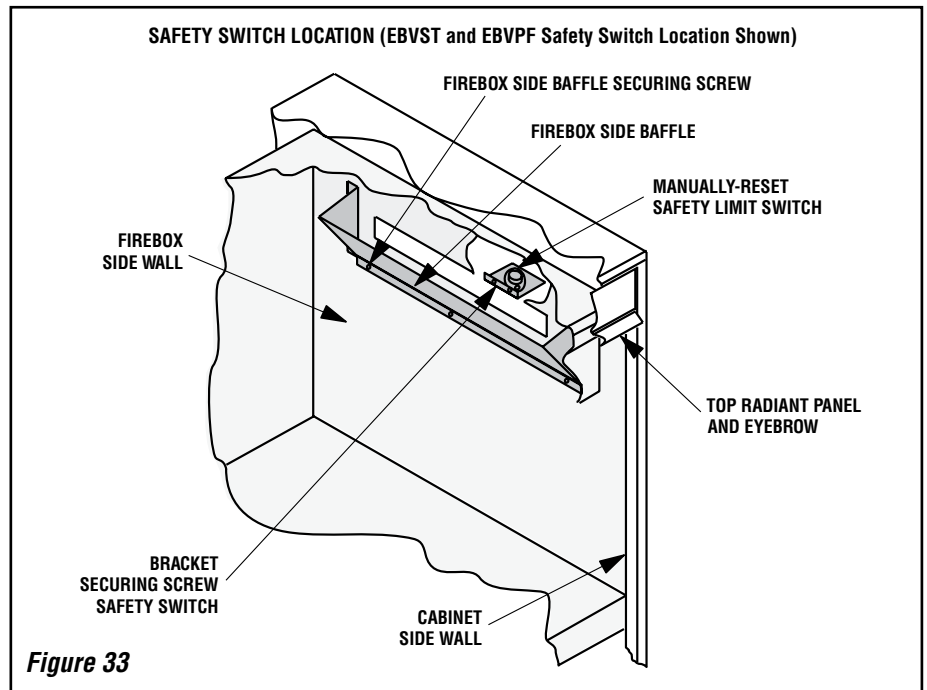

Figure 33

NOTE: DIAGRAMS & ILLUSTRATIONS ARE NOT TO SCALE.

STEP 13. ATTACHING SAFETY IN OPERATION WARNINGS

It is the installer's responsibility to ensure these warnings are properly affixed during installation. These warning labels are a critical step in informing consumers of safe operation of this appliance.

ATTACHING SAFETY-IN-OPERATION WARNINGS

Your fireplace has been furnished with safety instruction labels that are to be affixed to the operation and control point of the fireplace. A safety instruction label should be affixed to the wall switch plate where the fireplace is turned on and off (See **Figure A**) and if used on the remote control handheld transmitter (**Figure B**). The warnings should already have been put in place when the fireplace initial set-up was completed. If they are not affixed at these spots, locate the multi-lingual adhesive labels provided with these instructions and proceed as follows:

1. Locate the wall switch that controls the fireplace (verify the switch operates the fireplace by turning it on and off). Clean the wall switch plate thoroughly to remove any dust and oils. Affix the label to the surface of the plate of the wall switch that controls the fireplace (**Figure A**). Choose the language primarily spoken in the home.
2. If a remote control is used to control the fireplace, locate the transmitter and clean it thoroughly to remove any dust and oils. Affix the label to the surface of handheld transmitter (**Figure B**). Choose the language primarily spoken in the home.
3. If you are unable to locate the labels, please call Lennox Hearth Products or your nearest Lennox Hearth Products dealer to receive additional safety instruction labels free of charge.

Cat. No. H8024 Replacement Label Kit

LENNOX HEARTH PRODUCTS
1-800-9-LENNOX

Note: English is red text on clear label. French and Spanish are white text on black label.

SAFETY LABEL DIAGRAMS



Figure A



APPOSITION DES MISES EN GARDE RELATIVES À LA SÉCURITÉ D'UTILISATION

Votre foyer a été livré avec des étiquettes de sécurité qui doivent être collées à côté des dispositifs de contrôle du foyer. Une étiquette de sécurité devrait être collée sur la plaque de l'interrupteur contrôlant l'allumage du foyer (voir **Figure A**) et, le cas échéant, sur le boîtier de la télécommande (**Figure B**). Les mises en garde auraient dû être collées au moment de l'installation initiale du foyer. Si ce n'est pas le cas, prenez les étiquettes adhésives multilingues fournies avec ces instructions et procédez comme suit:

1. Repérez l'interrupteur qui contrôle le foyer (vérifiez que l'interrupteur contrôle le fonctionnement du foyer en le faisant basculer de Marche à Arrêt, et vice-versa). Nettoyez soigneusement la plaque murale de l'interrupteur pour éliminer la poussière et les traces de graisse ou d'huile. Collez l'étiquette sur la surface de la plaque de l'interrupteur mural qui contrôle le foyer (**Figure A**). Choisissez la langue qui est principalement parlée dans la résidence du propriétaire.
2. Si une télécommande est utilisée pour contrôler le foyer, nettoyez la soigneusement pour éliminer la poussière et les traces de graisse ou d'huile. Collez l'étiquette sur le boîtier de la télécommande (**Figure B**). Choisissez la langue qui est principalement parlée dans la résidence du propriétaire.
3. Si vous ne trouvez pas les étiquettes, veuillez appeler Lennox Hearth Products ou votre distributeur Lennox Hearth Products local pour recevoir gratuitement des étiquettes supplémentaires.

Étiquettes de remplacement, n° cat. H8024

LENNOX HEARTH PRODUCTS
1-800-9-LENNOX

Remarque : Le texte anglais est rouge sur un support transparent. Le texte français et espagnol est blanc sur un support noir.

DIAGRAMMES DES ÉTIQUETTES DE SÉCURITÉ



Figure B



COLOCACIÓN DE ADVERTENCIAS DE SEGURIDAD EN OPERACIÓN

Su chimenea incluye etiquetas de instrucciones de seguridad que deben colocarse en el punto de operación y control de la chimenea. Se debe colocar una etiqueta de instrucciones de seguridad en la placa del interruptor de pared desde el cual se enciende y se apaga la chimenea (ver la **Figura A**) y en el transmisor de control remoto (**Figura B**) si se usa. Las advertencias ya deben haberse colocado cuando se completó la instalación inicial de la chimenea. Si no están colocadas en estos lugares, encuentre las etiquetas adhesivas multilingües proporcionadas con estas instrucciones y prosiga de la siguiente manera:

1. Identifique el interruptor de pared que controla la chimenea (verifique que el interruptor opera la chimenea encendiéndola y apagándola). Limpie bien la placa del interruptor de pared para quitar el polvo y aceite. Pegue la etiqueta en la superficie de la placa del interruptor que controla la chimenea (**Figura A**). Seleccione el idioma que más se habla en la casa.
2. Si se usa un control remoto para controlar la chimenea, encuentre el transmisor y límpielo bien para quitar el polvo y aceite. Pegue la etiqueta en la superficie del transmisor (**Figura B**). Seleccione el idioma que más se habla en la casa.
3. Si no puede encontrar las etiquetas, sírvase llamar a Lennox Hearth Products o al distribuidor de Lennox Hearth Products más cercano para recibir etiquetas de instrucciones de seguridad adicionales gratuitas.

Juego de etiquetas de repuesto - N° de cat. H8024

LENNOX HEARTH PRODUCTS
1-800-9-LENNOX

Nota: La etiqueta en inglés es transparente con texto rojo. Las etiquetas en francés y español son negras con texto blanco.

DIAGRAMAS DE ETIQUETAS DE SEGURIDAD



GAS CONVERSION KITS

WARNING

This conversion kit shall be installed by a qualified service agency in accordance with the manufacturer's instructions and all applicable codes and requirements of the authority having jurisdiction. If the information in these instructions is not followed exactly, a fire, explosion or production of carbon monoxide may result causing property damage, personal injury or loss of life. The qualified service agency is responsible for the proper installation of this kit. The installation is not proper and complete until the operation of the converted appliance is checked as specified in the manufacturer's instructions supplied with the kit. The qualified service agency performing this installation assumes responsibility for this conversion.

AVERTISSEMENT

Cette trousse de conversion doit être installée par un technicien agréé, selon les instructions du fabricant et selon toutes les exigences et tous les codes pertinents de l'autorité compétente. Assurez-vous de bien suivre les instructions dans cette notice pour réduire au minimum le risque d'incendie, d'explosion ou la production de monoxyde de carbone pouvant causer des dommages matériels, des blessures ou la mort. Le technicien agréé est responsable de l'installation de cette trousse. L'installation n'est pas adéquate ni complète tant que le bon fonctionnement de l'appareil converti n'a pas été vérifié selon les instructions du fabricant fournies avec la trousse. Le fournisseur de service qualifié ayant réalisé l'installation assume les responsabilités liées à la conversion.

In Canada:

THE CONVERSION SHALL BE CARRIED OUT IN ACCORDANCE WITH THE REQUIREMENTS OF THE PROVINCIAL AUTHORITIES HAVING JURISDICTION AND IN ACCORDANCE WITH THE REQUIREMENTS OF THE CAN/CSA-B149.1 INSTALLATION CODE.

LA CONVERSION DEVRA ÊTRE EFFECTUÉE CONFORMÉMENT AUX RECOMMANDATIONS DES AUTORITÉS PROVINCIALES AYANT JURIDICTION ET CONFORMÉMENT AUX EXIGENCES DU CODE D'INSTALLATION CAN/CSA-B149.1.

Gas conversion kits are available to adapt your appliance from the use of one type of gas to the use of another. These kits contain all the necessary components needed to complete the task including labeling that must be affixed to ensure safe operation.

Kit part numbers are listed here and the following steps detail the conversion procedure. Refer to the instructions provided with the conversion kit when performing any gas conversion.

Natural To Propane Gas Conversion Kit		
Models No.	Unit Type	Catalog No.
EBVST EBVPF	millivolt	H2198
	electronic	H2200

Propane to Natural Gas Conversion Kit		
Model No.	Unit Type	Catalog No.
EBVST EBVPF	millivolt	H2199
	electronic	H2201

INSTALLATION INSTRUCTIONS

Step 1. TURN OFF THE GAS SUPPLY TO THE APPLIANCE and disconnect power supply at the circuit breaker. Ensure appliance is cold.

CAUTION: THE GAS SUPPLY SHALL BE SHUT OFF PRIOR TO DISCONNECTING THE ELECTRICAL POWER, BEFORE PROCEEDING WITH THE CONVERSION.

ATTENTION: AVANT D'EFFECTUER LA CONVERSION, COUPEZ D'ABORD L'ALIMENTATION EN GAZ, ENSUITE, COUPEZ L'ALIMENTATION ÉLECTRIQUE.

a. Open the control compartment access panel, by actuating the spring-loaded magnetic catches securing the panel, gently depressing the outer top corners of the panel until the catches "pop" the panel free and allowing it to swing out and down to open.

b. Remove the bottom control compartment access panel by compressing the spring-loaded hinge pin on the left side until it disengages from the left cabinet panel hole. Pull the panel away from the fireplace.

c. Remove the modesty panel by pulling the bottom right corner of the modesty panel out slightly to disengage the snap-fit feature; lift the modesty panel by the tab on the panel's right end, pull the right end of the panel away from the cabinet and then pull the panel diagonally out of the left side cabinet panel slots. Remove the modesty panel carefully, so that none of the wires become loose or disconnected.

d. Locate the two (2) latches at the top of the control compartment. To disengage the two latches from the bottom vee-flange of the glass enclosure panel, reach for the handles located towards the back of the latches and pull the handles down toward the front of the unit. See **Figure 29** on page 21.

e. Swing the bottom of the door out and raise it slightly to lift the top flange of the door frame away from the appliance.

Step 2. Carefully remove the log set. **Exercise care as not to break the log set.**

Step 3. Referring to **Figure 34**, remove the burner.

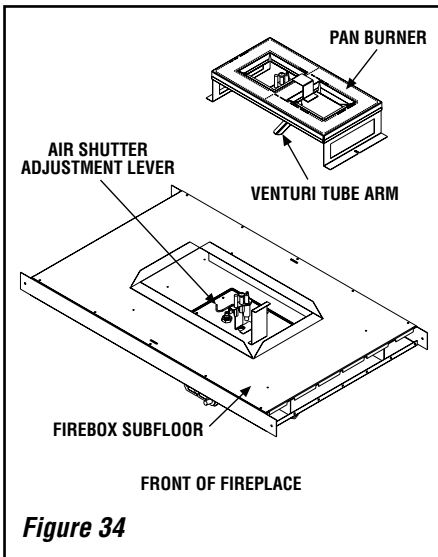

Figure 34

Millivolt Appliances

Step 4. Refer to **Figure 35** and the instructions provided with the kit. Using a Torx T20, remove and discard the three pressure regulator mounting screws. Remove the pressure regulator, spring, poppet, diaphragm and bushing. **Discard all removed components.** Ensure the rubber gasket installed on the back of the replacement pressure regulator is properly positioned and install the new pressure regulator using the new screws supplied with the kit. Tighten screws to 25 In. lb. torque.

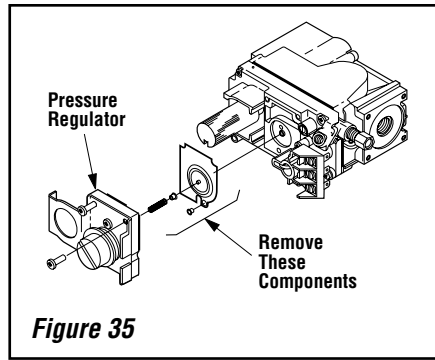

Figure 35

Step 5. Attach manometer to the manifold side pressure test fitting and verify manifold pressure reads 3.5 inches water column (0.87 kPa) for natural gas, and 10.0 inches water column (2.49 kPa) for propane gas.

Step 6. Refer to **Figure 36** and remove the pilot hood assembly to access the hexed pilot orifice. Remove and replace the orifice with the one provided with the kit.

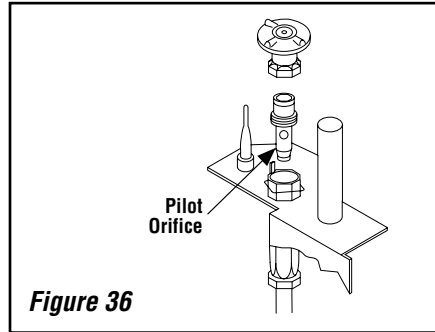

Figure 36

Electronic Appliances

Step 7. Honeywell Electronic Valves - See **Figure 37** and the instructions provided with the kit. Remove the slotted cap screw, o-ring, pressure-regulating adjusting screw and spring. Retain all parts for possible later use. Install new components from the kit. Black cap and red spring for propane gas units. Silver cap and stainless steel spring for natural gas units. Before installing the cap, attach manometer to the manifold side pressure test fitting and adjust screw until pressure reads 3.5 inches water column (0.87 kPa) for natural gas, and 10.0 inches water column (2.49 kPa) for propane gas.

See **Figure 38** and replace the pilot orifice as follows: Remove the ignitor assembly retainer clip, and carefully remove the ignitor assembly.

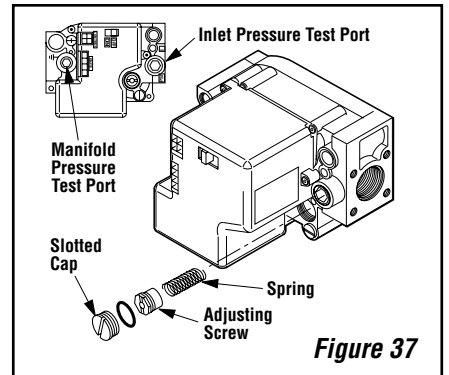
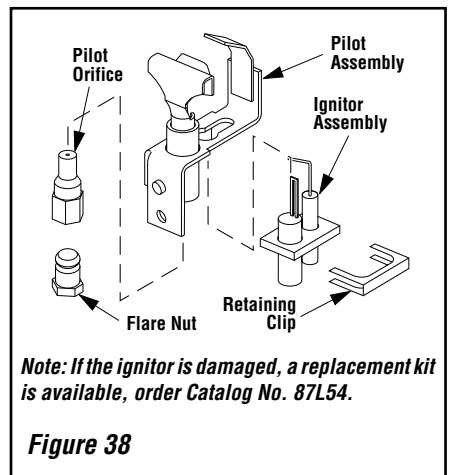

Figure 37

Exercise extreme care to prevent damage to or breakage of the ignitor assembly.

Remove the screw securing the pilot assembly to its mounting bracket. Back off the flare nut at the end of the pilot gas line to free the pilot assembly from the gas line. Remove the pilot orifice and replace it with the one provided with the conversion kit. Reinstall the pilot assembly by reversing the **steps** detailed here.

When reinstalling the ignitor assembly, use extreme care to prevent damage and breakage. Do not apply any leverage to the ignitor assembly while restoring the retainer clip to its original position.



Note: If the ignitor is damaged, a replacement kit is available, order Catalog No. 87L54.

Figure 38

All Models

Step 8. (Refer to **Figure 34**)

A. Remove the orifice from the manifold and replace it with the one provided in the kit. The following table shows the orifice sizes for natural and propane models. **Figure 39** illustrates the orifice. Always check and verify correct orifice size.

B. Install the burner as shown in *Figure 40*.

Ensure that the arm of the venturi of the burner is hooked onto the air shutter adjustment lever (refer to *Figure 34 on page 26*). The primary air opening can be adjusted by rotating the adjustment lever from beneath the firebox floor. Refer to *Figure 31 on page 22* for the recommended minimum primary air opening setting.

Burner Orifice Sizes (all models)		
Elevation Feet (meters)	Natural Gas drill size (inches)	Propane Gas drill size (inches)
0-4500 (0-1372)	(0.125") * 21L81 •	#41 (0.096")* 21L82 •
<i>Table 7</i> * Standard size installed at factory • Part /Cat. Number		

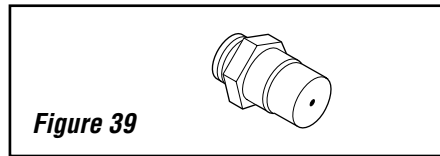

Figure 39

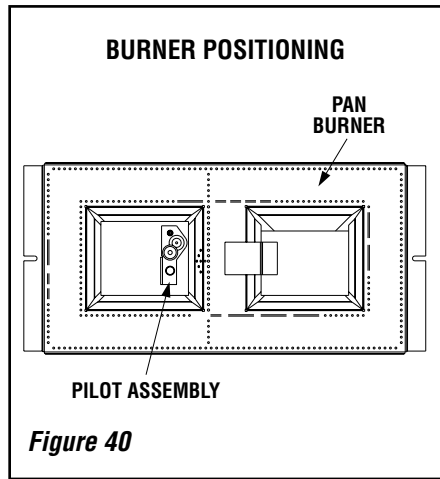

Figure 40

Step 9. Reassemble the remaining components by reversing the procedures outlined in the preceding steps.

Use pipe joint compound or Teflon tape on all pipe fittings before installing (ensure propane resistant compounds are used in propane applications, do not use pipe joint compounds on flare fittings).

Step 10. Attach the conversion label provided in the conversion kit to the rating plate on the appliance.

Step 11. Turn on gas supply and test for gas leaks.

ALWAYS TEST PRESSURE WITH THE VALVE REGULATOR CONTROL AT THE HIGHEST SETTING

Lennox Hearth Products reserves the right to make changes at any time, without notice, in design, materials, specifications, prices and also to discontinue colors, styles and products. Consult your local distributor for fireplace code information.



HEARTH PRODUCTS

Printed in U.S.A. © 2004 Lennox Hearth Products
P/N 850025M REV. E 01/2011

1508 Elm Hill Pike, Suite 108 • Nashville, TN 37210