



HEARTH PRODUCTS

INSTALLATION INSTRUCTIONS

MERIT® SERIES

36" Wood Burning Fireplaces
P/N 850,048M REV. A 03/2008

MODELS

CR-3835R

CR-3835L

This installation manual will enable you to obtain a safe, efficient and dependable installation of your fireplace system. Please read and understand these instructions before beginning your installation.

Do not alter or modify the fireplace or its components under any circumstances. Any modification or alteration of the fireplace system, including but not limited to the fireplace, chimney components and accessories, may void the warranty, listings and approvals of this system and could result in an unsafe and potentially dangerous installation.

**IMPORTANT! TO ASSURE PROPER ALIGNMENT OF GLASS DOORS:
INSTALL THIS FIREPLACE IN A SQUARE AND PLUMB CONDITION,
USING SHIMS AS NECESSARY AT SIDES AND/OR BOTTOM.**

NATIONAL
FIREPLACE
INSTITUTE



CERTIFIED

www.nficertified.org

We suggest that our woodburning hearth products be installed and serviced by professionals who are certified in the U.S. by the National Fireplace Institute® (NFI) as NFI Woodburning Specialists or who are certified in Canada by Wood Energy Technical Training (WETT).



RETAIN THESE INSTRUCTIONS FOR FUTURE REFERENCE

Tested &
Listed By



Beaverton
Oregon USA

OMNI-Test Laboratories, Inc.

OTL Report No. 116-F-20-4

TABLE OF CONTENTS

Safety Rules	page 2
Tools and Building Supplies	page 2
Precautions	page 2
Introduction	page 3
Chimney/Mantel Clearances And Height Requirements	page 3
Chimney System	page 3
Assembly Outline	page 4
Location of Fireplace	page 4
Assembly Steps	page 5
Preinstallation Notes	page 5
Fireplace Clearances	page 5
Installing the Fireplace	page 5
Fireplace Specifications	page 6
Framing Specifications	page 7
Installing the Chimney System	page 8
30° Offset through Floor/Ceiling	page 9
Ten Foot Rule Summary	page 11
Multiple Terminations	page 11
Chimney Component Calculations ...	page 11
Special Offset Instructions	page 11
Offset Calculations	page 12
Vertical Elevation Chart	page 13
Offset Elevation Chart	page 15
Installing Offsets	page 17
Combustion Air Kits	page 17
Gas Line Connection	page 17
Glass Doors	page 18
Cold Climate Insulation	page 18
Fireplace Finishes	page 18
Mantels and Trim	page 18
Hearth Extensions/Wall Shields	page 18
Finish Requirements	page 20
Installation Components	page 21

This manual is part of a set of two supporting this product. Refer to manual 875,040M for Care and Operation instructions.

IMPORTANT: PLEASE READ AND UNDERSTAND THESE RULES TO FOLLOW FOR SAFETY.

1. Before starting your fireplace installation, read these installation instructions carefully to be sure you understand them completely and in entirety. Failure to follow them could cause a fireplace malfunction resulting in serious injury and/or property damage.

2. Always check your local building codes. The installation must comply with all local, regional, state and national codes and regulations.

3. These fireplaces must be installed with either Security Chimneys model FTF8 (8" [203mm] inside diameter) or FTF10 (10" [250mm] inside diameter) Chimney System only. These systems are intended for use in any application where a traditional masonry type fireplace would apply. The chimney system must always vent to the outside of the building.

4. To ensure a safe fireplace system and to prevent the build-up of soot and creosote, inspect and clean the fireplace and chimney prior to use and periodically during the heating season.

5. Use solid fuel only. DO NOT use artificial wax based logs, chemical chimney cleaners or flame colorants in your fireplace.

6. DO NOT use charcoal or coal under any circumstances.

7. NEVER use gasoline, gasoline-type lantern fuel, kerosene, charcoal lighter fluid, or similar liquids to start or "freshen up" a fire in this fireplace. Keep any flammable liquids a safe distance from the fireplace.

8. NEVER leave children unattended when there is a fire burning in the fireplace.

9. Always keep flue damper open when heat is present in the fireplace.

10. Before servicing, allow the fireplace to cool. Always shut off any electricity or gas to the fireplace while working on it. This will prevent any possible electrical shock or burns.

11. This fireplace is not intended to heat an entire home or be used as a primary heat source. It is designed to ensure homeowner comfort by providing supplemental heat to the room.

12. Always ensure an that adequate supply of replacement combustion air from the outside of the house is accessible to the fire to support normal combustion. Fireplaces consume large volumes of air during the normal combustion process. In the event the home is tightly sealed with modern energy efficient features, the optional combustion air kit may not provide all the air required to support combustion.

The manufacturer is not responsible for any smoking or related problems that may result from the lack of adequate combustion air. It is the responsibility of the builder/contractor to ensure that adequate combustion air has been provided for the fireplace.

13. DO NOT use a fireplace insert or any other products not specified herein by the manufacturer for use with this fireplace. All gas log sets must be operated with the damper clamped open.

WARNING: THIS FIREPLACE HAS NOT BEEN TESTED WITH AN UNVENTED GAS LOG SET. TO REDUCE RISK OF FIRE OR INJURY, DO NOT INSTALL AN UNVENTED GAS LOG SET INTO THIS FIREPLACE.

14. "Smoke free" operation is not warranted nor are we responsible for inadequate system draft caused by mechanical systems, general construction conditions, inadequate chimney heights, adverse wind conditions and/or unusual environmental factors or conditions beyond our control.

15. Never, under any circumstances, install a fireplace, chimney component or any accessories, that has visible or suspected physical damage as a result of handling or transportation. These items should be inspected by your distributor or qualified factory representative to ensure safe condition. When in doubt, consult your distributor.

16. For additional safety considerations and complete operating instructions, refer to the Care and Operation Manual provided with the fireplace.

TOOLS AND BUILDING SUPPLIES NORMALLY REQUIRED

Tools should include:

- Phillips screwdriver
- Hammer
- Saw and/or sabersaw
- Level
- Measuring tape
- Plumb line
- Electric drill and bits
- Pliers
- Square

Building supplies:

- Framing materials
- Wall finishing materials
- Caulking materials (noncombustible)
- Fireplace surround and hearth extension materials (noncombustible)

PRECAUTIONS

Note: These fireplace systems are not difficult to install. However, in the interest of safety, it is recommended that the installer be a qualified or certified "tradesman" familiar with commonly accepted fireplace installation and safety techniques as well as prevailing local codes.

The most important areas of concern dealing with the installation of factory-built fireplaces are clearances to combustible materials, proper assembly of component parts, height of the chimney system, the proper use of accessories supplied by the manufacturer and the techniques employed in using finishing materials applied to the wall surrounding the fireplace, hearth extensions and wall shields. Each of these topics will be covered in thorough detail throughout this manual. Please give each your special attention as you progress with your installation.

INTRODUCTION

General Information

These fireplaces are conventional radiant heat fireplaces with standard bar grates, optional outside combustion air kits and optional decorative glass doors.

These fireplaces have been tested and listed by Omni Test Labs (Report No.116-F-20-4) to U.L. standard 127. These units are intended for installation in residential homes and other buildings of conventional construction including commercial, not in mobile homes.

TYPICAL INSTALLATION

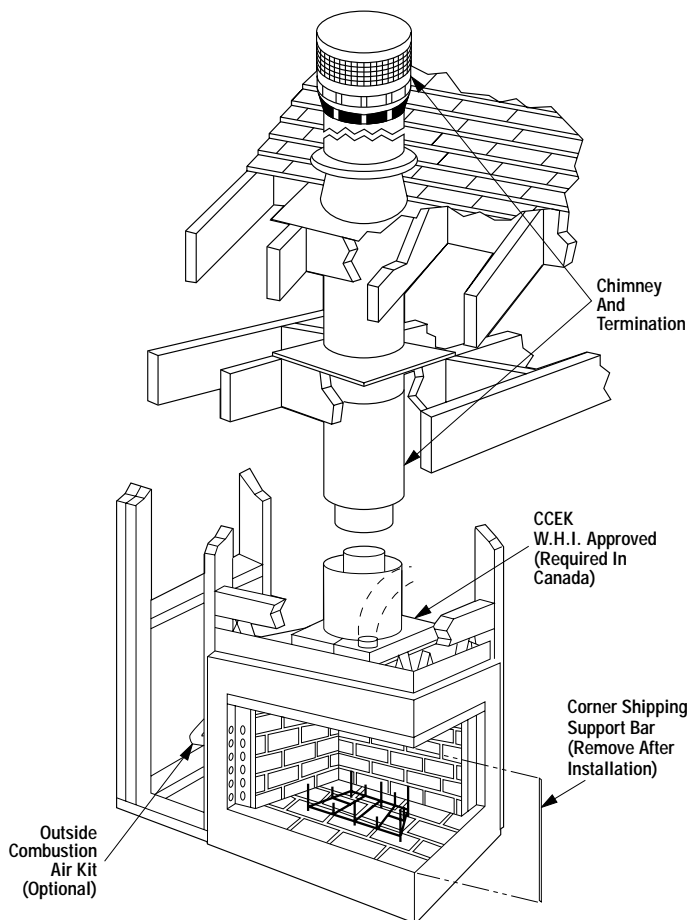

Figure 1

Note: Illustrations shown reflect "typical" installations with nominal dimensions and are for design and framing reference only. Actual installations may vary due to individual design preferences. However, always maintain minimum clearances to combustible materials and do not violate any specific installation requirements.

These fireplace systems are designed for installation in accordance with the National Fire Protection Standard for chimneys, fireplaces and solid fuel burning appliances; NFPA 211 and in accordance with codes such as the BOCA Basic/National Codes, the Standard Mechanical Code and the Uniform Building Codes.

WARNING: FAILURE TO USE MANUFACTURE PROVIDED PARTS, VARIATIONS IN TECHNIQUES AND CONSTRUCTION MATERIALS OR PRACTICES OTHER THAN THOSE DESCRIBED IN THIS MANUAL MAY CREATE A FIRE HAZARD AND VOID THE LIMITED WARRANTY.

NOTE: DIAGRAMS & ILLUSTRATIONS NOT TO SCALE.

When complete these fireplace systems consists of five basic "sub-systems":

1. The Fireplace
2. The Chimney and Termination
3. The Optional Glass Doors
4. The Optional Combustion Air Kits
5. The Chimney Collar Enclosure Kit (Canada Only) or Collar Duct Kit (U.S)

CHIMNEY CLEARANCES AND MANTEL HEIGHT REQUIREMENTS

The fireplace may be placed on or near normal construction materials*. The combustion air kit, firestop spacer and roof flashings (not chase flashings) may be placed directly on or against normal construction materials*. **The chimney requires a minimum 2" (51 mm) air space to combustibles** (See **Note). A combustible mantle may be installed 12" (305 mm) above the opening of the fireplace as per NFPA 211, Section 7-3.3.3. In Canada the minimum is 18" (457 mm) above the opening.

The fireplace and chimney system must be enclosed when installed in or passing through a living area where combustibles or people may come in contact with it. This is important to prevent possible personal injury or fire hazard.

For questions, please call your distributor or the manufacturer. Special restrictions apply to the front and facing of the fireplace and nearby walls (See pages 16, 17 and 18).

CHIMNEY SYSTEM

These fireplaces are designed and code listed for use with Security's FTF8 and FTF10 chimney System only. Always use Security's FTF8 and FTF10 chimney components with these fireplaces. Do not modify or alter these components as this may cause a potential serious hazard and void the Warranty.

*Construction Materials:

- framing materials
- particle board
- dry wall
- plywood
- paneling
- flooring
- etc.

** Note: 1" (25 mm) when installed with FTF10 in the U.S. only.

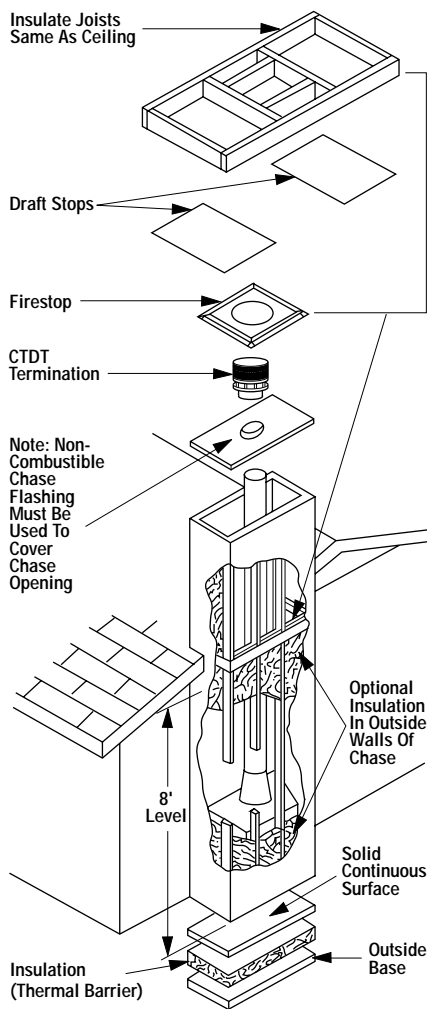

Figure 2

WARNING: IF INSULATION IS USED, THE FIREPLACE MUST NOT BE PLACED DIRECTLY AGAINST IT. INSULATION OR VAPOR BARRIERS, IF USED, MUST FIRST BE COVERED WITH GYPSUM BOARD, PLYWOOD, PARTICLE BOARD OR OTHER MATERIAL TO ASSURE INSULATION AND VAPOR BARRIERS REMAIN IN PLACE.

WARNING: DO NOT PACK OR FILL REQUIRED AIR SPACES WITH INSULATION OR OTHER MATERIAL. NO MATERIAL IS ALLOWED IN THESE AREAS.

Note: Do not insulate the chase cavity with blown or fill type insulation materials.

Note: Local codes may not require firestopping at the ceiling levels for outside chase installations. However, it is recommended for safety and the reduction of heat loss.

Chimney Height

The total height of your completed fireplace system from the surface the fireplace rests on to the chimney top must not exceed 50' (15.24 m) and must also meet minimum height requirements. Refer to the minimum system height chart.

Minimum System Height

	FTF10	FTF8
Vertical Installation	15'2" (4.62 m)	16'8" (5.08 m)
One Offset	15'2" (4.62 m)	16'8" (5.08 m)
Two Offsets	25'0" (7.62 m)	25'0" (7.62 m)

Chase Enclosure

A chase is a vertical box-like structure constructed to surround the fireplace and chimney. Refer to Figure 2 for a typical chase configuration. As with all chimney installations, avoid overhead obstructions such as trees, power lines, etc. A chase should be constructed and insulated just like any outside wall. In a cold climate, we recommend the base of the chase should also be insulated between the solid continuous floor beneath the fireplace and the chase bottom. Chase insulation in a cold climate installation is not required for safety.

ASSEMBLY OUTLINE Before You Start

Check your inventory list to be sure you have all the necessary parts supplied in good usable condition. Check also for any concealed damage.

Check the operation of the damper. The damper is controlled through the use of a control lever located within the firebox opening at the top center just behind the firebox lintel (Figure 3). The control lever snaps into place at the extreme range of motion, up and back in the closed position. When pulled forward and down, the damper is open.

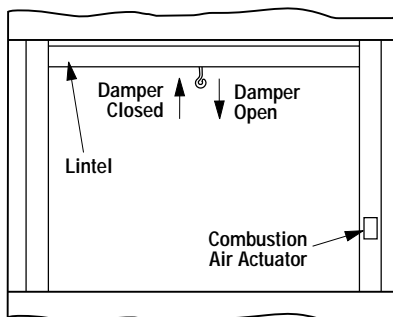

Figure 3

NOTE: DIAGRAMS & ILLUSTRATIONS NOT TO SCALE.

LOCATION OF FIREPLACE

Carefully select the proper location for heat circulation, aesthetics, chimney obstructions and clearance to side wall(s). With proper pre-planning, a slight adjustment of a few inches can save considerable time and expense later during construction and assembly.

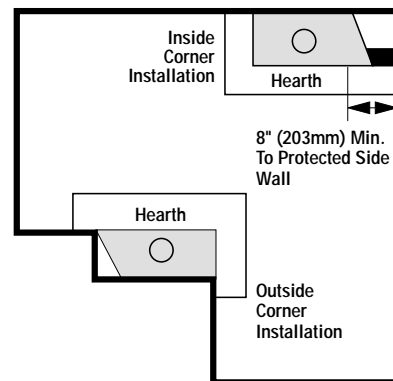

Figure 4

Carefully consider the position of the fireplace opening with respect to the location of adjacent or nearby stairwells, bath or kitchen exhaust fans and/or return air registers for forced air furnaces/air conditioners that could cause a smoking fireplace condition if the house is tightly insulated.

When locating the fireplace, consideration must be given to combustibles and final finishing. See Figure 5 and confine the final location of combustible finish materials to the "Safe Zone".

DO NOT permanently place furniture or other items such as decorative pillows within 60" of the fireplace front face.

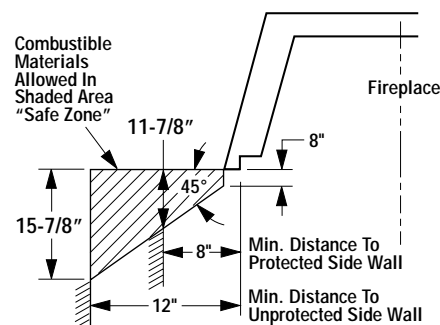

Figure 5

ASSEMBLY STEPS

Note: The following steps represent the normal sequence of installation. Each installation is unique, however, and might require a different sequence.

1. Position firebox prior to framing or into prepared framing.
2. Install the chimney system.
3. Connect house wiring to the fireplace for later attachment of optional blower.
4. Install optional outside combustion air kit.
5. Plumb gas line if a decorative gas appliance will be used. (Gas connections should only be performed by an experienced, licensed/certified tradesman.)
6. Complete the installation, finish wall material, surround and hearth extension to your individual taste.
7. Assemble and attach optional glass door assembly.

Study the three dimensional illustration (Figure 1) to get a general idea of each element of your fireplace system.

PRE-INSTALLATION NOTES

The fireplace may be installed directly on a combustible floor or raised on a platform of an appropriate height. Do not place fireplace on carpeting, vinyl or other soft floor coverings. It may, however, be placed on flat wood, plywood, particle board or other hard surfaces. Be sure fireplace rests on a solid continuous floor or platform with appropriate framing for support and so that no cold air can enter the room from under the fireplace.

The fireplace may be positioned and then the framing built around it, or the framing may be constructed and the fireplace positioned into the opening.

Note: Framing must be constructed in such a manner as to be capable of supporting all of the weight of the finished material above the fireplace. Do not support any building weight with this fireplace. After construction, remove the corner shipping support bar (refer to Figure 1).

Usually, no special floor support is needed for the fireplace, however, to be certain:

1. Estimate the total weight of the fireplace system including chimney and surround materials such as brick, stone, etc., to be installed. Shipping weights for the fireplace may be found on page 18.

2. Measure the square footage of the floor space to be occupied by the system, surrounds and hearth extensions.

3. Note the floor construction, i.e. 2 x 6's, 2 x 8's or 2 x 10's, single or double joists, type and thickness of floor boards.

4. Use this information and consult your local building code to determine if you need additional support.

CAUTION: DO NOT BLOCK THE HEAT-CIRCULATING AIR INLET AND OUTLET PORTS ON CIRCULATING MODELS. DOING SO MAY RESULT IN A POTENTIAL FIRE HAZARD.

If you plan to raise the fireplace and hearth extension, build the platform assembly then position fireplace and hearth extension on top. Secure the platform to the floor to prevent possible shifting.

FIREPLACE CLEARANCES

Minimum clearance to combustibles for the appliance is as follows: sides and back - 1/2" (13 mm), floor - 0" (0 mm), adjacent wall - 12" (305 mm), ceiling - 37-1/2" (953 mm).

INSTALLING THE FIREPLACE

Step 1. Slide the fireplace into prepared framing or position fireplace in its final position and frame later.

The fireplace may not be recessed into a combustible floor. Maintain the floor to hearth clearance established by the fireplace lower front face.

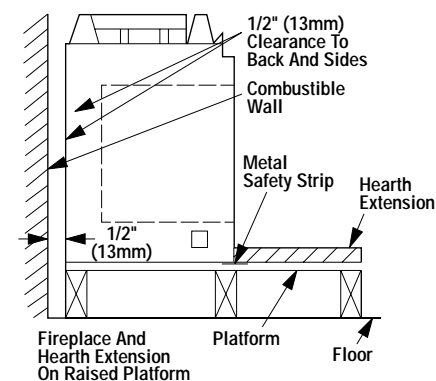

Figure 6

Step 2. Insert the provided metal safety strips, beneath the fireplace as illustrated in Figures 6, 7 and 8. The safety strips should overlap 1/2" for continual coverage of the floor.

Note: Safety strips are not required when fireplace rests on a noncombustible surface.

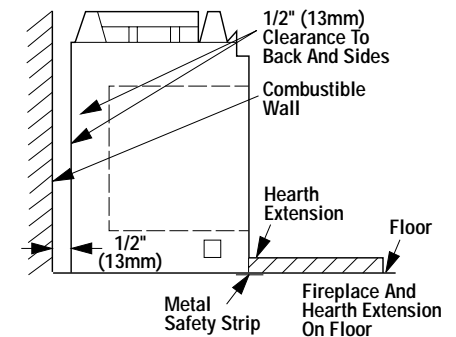

Figure 7

Note: Install the hearth extension only as illustrated.

The safety strips should extend from front of the fireplace at least 1-1/2" and should extend to be at least flush with the sides. In the event a wooden support is used to elevate the fireplace above the floor, a "Z" type safety strip should be fabricated and used to protect the front surface of the wood support as well as the floor beneath the hearth extension (Figures 8 and 9). The safety strips should be tacked down to prevent possible movement.

Note: The "Z" type safety strip is not supplied.

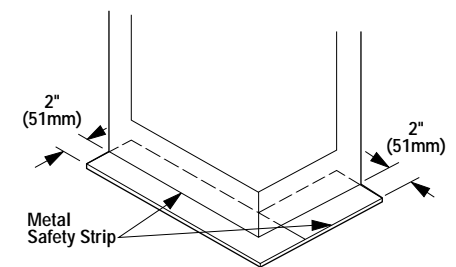

Figure 8

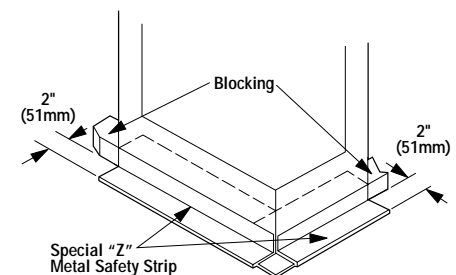

Figure 9

Step 3. Refer to the Fireplace Specifications (Figure 11) for framing dimensions and details. Frame appliance enclosure as illustrated in Figures 12 through 14 on page 7.

IMPORTANT: UNDER NO CIRCUMSTANCES CAN THE FIREPLACE TOP SPACERS (FIGURE 6) BE REMOVED OR MODIFIED, NOR MAY YOU NOTCH THE HEADER TO FIT AROUND OR BE INSTALLED LOWER THAN THE SPACERS. THE HEADER MAY BE IN DIRECT CONTACT WITH THE TOP SPACERS BUT MAY NOT BE SUPPORTED BY THEM.

Note: The framed depth, 24 (610 mm) from a framed wall, must always be measured from a finished surface. If a wall covering such as drywall is to be attached to the rear wall, then the 24" (610 mm) must be measured from the drywall surface. It is important that this dimension be exact.

If the appliance is to be elevated above floor level, a solid continuous platform must be constructed.

The header may rest on the top metal spacers, but must not be notched to fit around them.

Consult all local codes.

**For Canadian Installations
Proceed with Steps 4 through 7.**

Step 4. Attach the chimney collar enclosure kit, Model CCK1, around chimney collar with the screws provided (Figure 10).

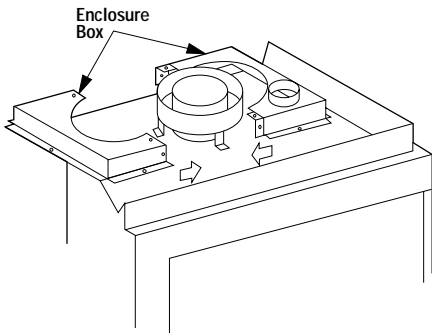

Figure 10

Step 5. Connect the 4" (102 mm) Class 0 air duct provided to the collar on the chimney collar enclosure with the screws provided in the hardware kit.

FIREPLACE SPECIFICATIONS

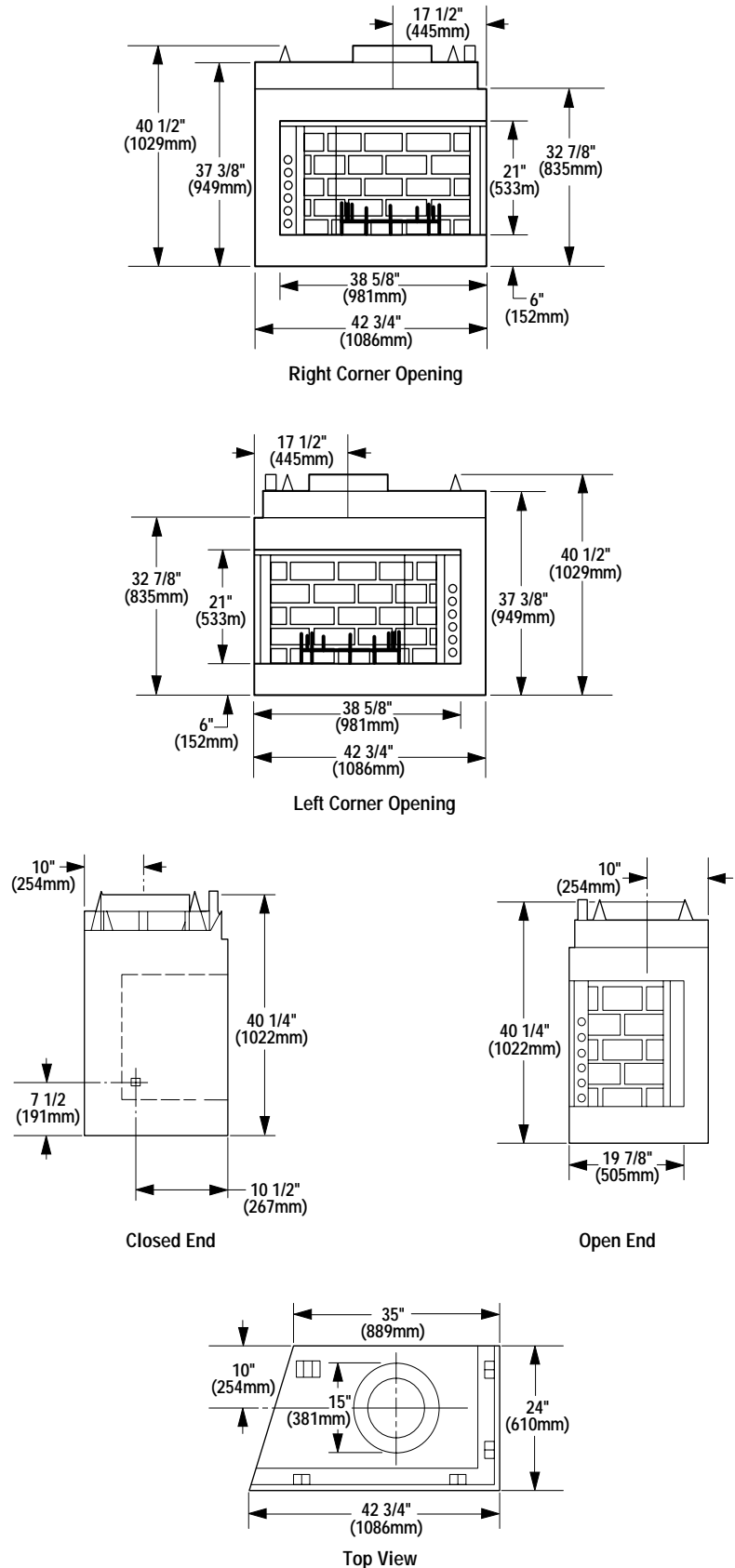
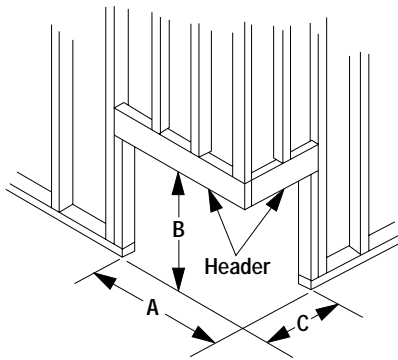

Figure 11

NOTE: DIAGRAMS & ILLUSTRATIONS NOT TO SCALE.

FRAMING SPECIFICATIONS



Framing Without False Header

Figure 12

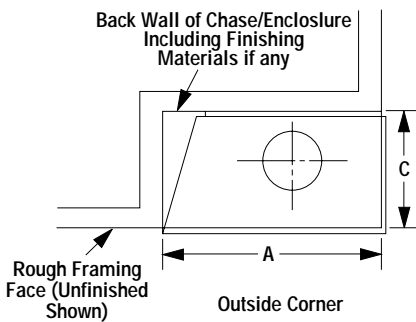

Figure 13

Framing Dimensions for Ceiling

Flue Type	A	B
FTF8 Vertical at 2"	16-1/2" (419 mm)	16-1/2" (419 mm)
FTF10 Vertical at 1"	17" (432 mm)	17" (432 mm)
FTF10 Vertical at 2"	19" (483 mm)	19" (483 mm)
FTF8 Offset 30° at 2"	16-1/2" (419 mm)	27" (686 mm)
FTF10 Offset 30° at 1"	17" (432 mm)	26" (660 mm)
FTF10 Offset 30° At 2"	19" (438 mm)	28" (711 mm)

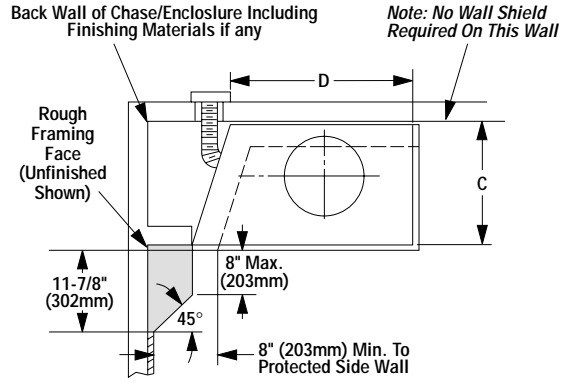

Figure 14

Note: Combustible Materials May Be Placed In Shaded Area.

Inside Corner Using Outside Air

Framing Dimensions CR-3835 Series

A	42-5/8" (1082 mm)
B	40-5/8" (1032 mm)
C	24" (610 mm)
D	34-7/8" (886 mm)

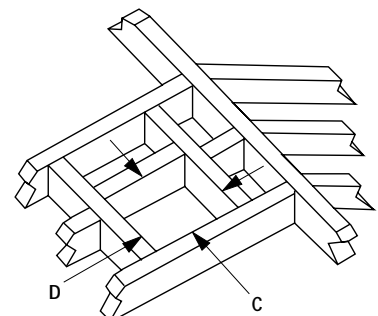

Roof Framing

Figure 15

Note: All framing dimensions calculated for 5/8" nailing flange depth at the fireplace face. If sheathing the chase or finishing with other thickness materials, calculations will need to be made.

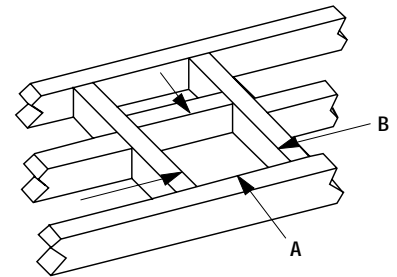

Ceiling Framing

Figure 16

Framing Dimensions for Roof

Pitch	FTF8 at 2"		FTF10 at 1"		FTF10 at 2"	
	C	D*	C	D*	C	D*
0/12	16-1/2" (419 mm)	16-1/2" (419mm)	17" (432 mm)	17" (432 mm)	19" (483 mm)	19" (483 mm)
6/12	16-1/2" (419 mm)	19" (483 mm)	17" (432 mm)	19" (483 mm)	19" (483 mm)	21" (533 mm)
12 /12	16-1/2" (419mm)	23-1/2" (597mm)	17" (432mm)	24" (610 mm)	19" (483mm)	26" (660 mm)

*Perpendicular to roof ridge

Step 6. Route the Class 0 air duct out the back wall or side wall, up through the ceiling or floor joists to an outside wall. The air duct should be located above snow level.

Note: If the fireplace is installed against an inside wall, the Class 0 air duct may be extended into a ventilated attic space at least 18" (457 mm) above the attic floor. Secure the duct hood to a vertical post with the inlet positioned downward. Ensure nothing blocks the hood opening. This air duct must never terminate higher than the chimney.

Step 7. Cut or frame hole through the outside wall for the installation of the duct inlet hood. A 4-1/4" (114 mm) diameter hole is sufficient. Feed the loose end of the flexible air duct through the hole cut for the inlet hood and attach to collar on inlet hood using two (2) screws. Insert hood into opening. Secure in place with nails driven through holes in hood flange. Seal with noncombustible waterproof silicon type caulking. If additional air duct is needed, use Class 0 metallic air duct.

Step 8. Fireplace should be secured to side framing members using the full length nailing tabs at the top and bottom of the fireplace front face. Use 8d nails or equivalent (Figure 17).

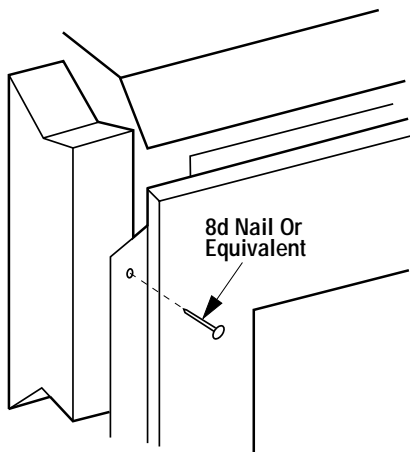

Figure 17

Note: The nailing tabs may make direct contact with combustible framing. Maintain at least 1/2" clearance from the firebox wrapper to the framing at the closest point of contact, directly adjacent to the flange.

INSTALLING THE CHIMNEY SYSTEM

Step 1. Before continuing, check the operation of the damper, as described on page 4, (refer to Figure 3).

Step 2. Using standard construction framing techniques, construct opening for chimney route up through the ceiling(s) and roof or through an outside chase.

Framing must maintain adequate minimum air space clearance at all times.

CAUTION: ALLOW MINIMUM 2" (51 MM) CHIMNEY AIR SPACE TO COMBUSTIBLE FRAMING MEMBERS THROUGHOUT VERTICAL OR OFFSET CHIMNEY INSTALLATION (SEE **NOTE).

Reference Figures 14 and 15 and charts Framing Dimensions for Ceiling and Roof, which specify minimum ceiling and roof dimensions.

To determine chimney center line in new construction, use plumb line from roof or ceiling above fireplace to center of flue collar on fireplace.

For remodeling, plumb to center of flue collar from ceiling above, drive nail through ceiling from below to mark position, then mark and cut to passage from above ceiling (around nail) (Figure 18). Then plumb from ceiling or roof level directly above hole which has just been completed.

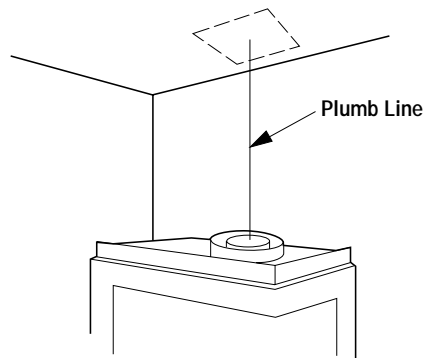

Figure 18

Note: If installing the optional collar duct kit, it should be installed after the chimney has been attached to the flue collar.

Step 3. Position appropriate firestop spacer at ceiling and fasten temporarily with two (2) 8d nails or equivalent. If chimney penetrates ceiling vertically, use flat firestop spacer, Model F8FS-2 for FTF8 system and Model F10FS-2 for the FTF10 system*. If chimney penetrates ceiling at 30° angle (offset chimney), use 30° firestop spacer, Model F8FS30-2 for FTF8 and Model F10FS30-2 for FTF10 system*. Use one nail on opposite sides to hold firestop spacer in position. Fasten permanently, using at least two (2) more 8d nails or equivalent, after chimney sections have been assembled through the firestop spacer and after any necessary adjustments have been made. Firestop spacer must be secured by at least four (4) 8d nails or equivalent when completely installed.

Note: If there is a room above ceiling level, firestop spacer must be installed on the bottom side of the ceiling. If an attic is above ceiling level, firestop spacer must be installed on top side of ceiling joist (Figures 19 and 20).

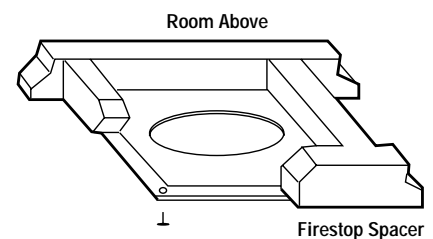

Figure 19

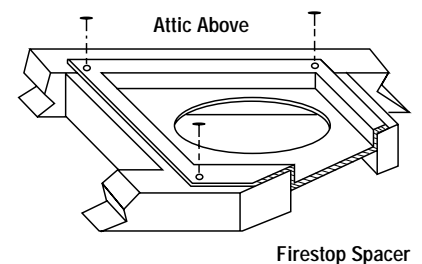

Figure 20

***Note:** Use Models F10FS or F10FS30 when installing FTF10 chimney in the U.S. only.

**** Note:** 1" (25 mm) when installed with FTF10 in the U.S. only.

CHIMNEY 30° OFFSET THROUGH FLOOR OR CEILING

It may be necessary to assemble the chimney at 30° when passing through the floor or ceiling area. Use the F8FS30-2 firestop spacer as shown in *Figures 21 and 22*. Support the chimney at floor or ceiling penetration with a FTF8 stabilizer if distance of chimney below ceiling is 10' or more. Maintain 2" minimum air space to combustibles from chimney sections.

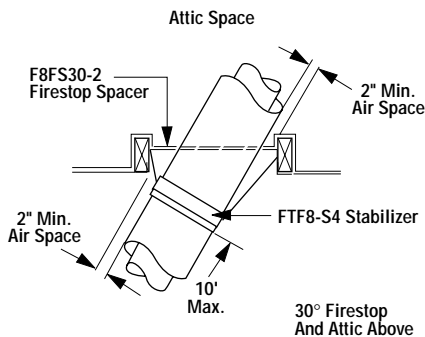

Figure 21

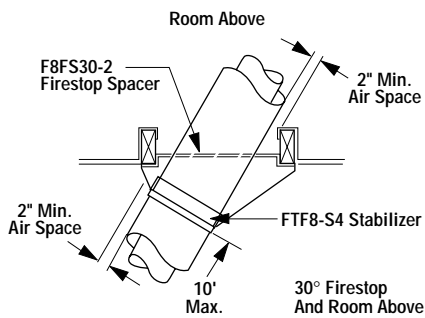

Figure 22

Step 4. Note: Chimney sections are constructed with a unique locking tab design, which ensures an immediate, tight assembly between sections. Plan your chimney requirements carefully before assembly as chimney is difficult to disassemble after installation. If disassembled, the tabs might become damaged. Be certain tabs are properly formed to ensure locking tabs engage properly.

Security's FTF8 and FTF10 chimney systems are two piece chimneys, which snap together from the fireplace up. Start with the inner flue section. With the lanced end up, snap lock it into the matching collar on top of the fireplace.

At all subsequent joints, the upper flue section fits into the preceding flue section. Each piece snaps together by means of locking tabs (9 locking tabs per joint). Check each piece by pulling up slightly from the top to ensure proper engagement before installing the next section. If the flue has been installed correctly, it will not separate when you test it. Also, the inner flue joint where each section is joined should be tight and flat without gaps (*Figure 23*).

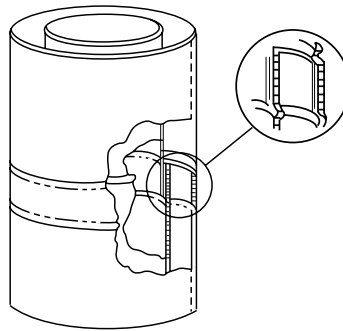

Figure 23

Outer pipe section installs in just the opposite way; the lanced end goes down and each new section goes OVER the outside of the previous section installed (*Figure 24*).

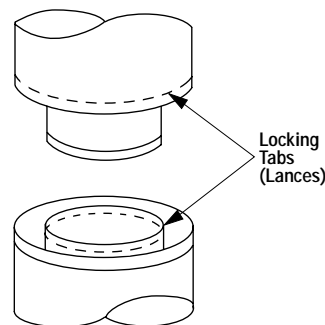

Figure 24

Note: Assemble one component of chimney at a time (inner section first, then outer section last) before proceeding with the next complete section.

Continue to assemble the chimney up through framed opening. Assemble just enough to penetrate the roof flashing openings (*Figure 25*).

**** Note:** 1" (25 mm) when installed with FTF10 in the U.S. only.

Always maintain 2" (51 mm) minimum air space to combustible materials and always check each chimney joint (inner and outer) to ensure proper engagement (*See **Note*). Check vertical alignment of chimney so that it projects from the roof in true vertical position.

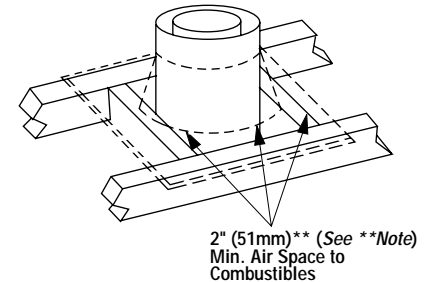

Figure 25

Security's chimney sections do not need to be screwed together. Additional reinforcement is not necessary except in certain offset conditions (refer to page 14, *Figure 36*).

Step 5. The height of vertical chimney pipe supported only by the fireplace must not exceed 30' (9.1 m). Chimney heights above 30' (9.1 m) must be supported by a Model F8-S4 or Model F10-S4 stabilizer installed at 30' (9.1 m) intervals.

Note: The Model F8-S4 and Model F10-S4 add 3" (76 mm) net effective height to the total chimney system.

Install Model F8-S4 or F10-S4 stabilizer by fitting inner section down into respective section of proceeding flue pipe and locking outer stabilizer section into place over the outer chimney pipe. Position for proper clearance through framed opening and nail straps securely (under tension in "shear") into place on framing. Use 8d nails or equivalent. Attach successive lengths of chimney pipe directly to stabilizer using same techniques as described in Step 4 (*Figure 26*).

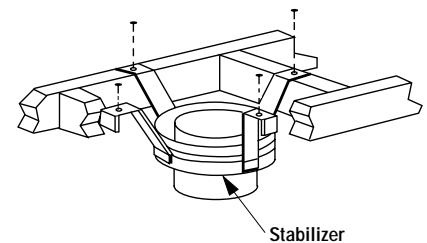

Figure 26

Note: Do not apply excessive pressure to any subsequent chimney sections following the stabilizer when installing. Ensure each subsequent chimney section is securely attached by testing as noted in Step 4.

Step 6. Select the proper Security Chimneys roof flashing based on pitch of roof. Use chart below for selection:

Roof Pitch	FTF8	FTF10
Flat to 6/12	F8-F6	F10-F6
6/12 to 12/12	F8-F12	F10-F12

Next, slide roof flashing over extended chimney section that previously has been installed above the roof opening in Step 4. Slide flashing all the way down until the flashing base rests flat on the roof. Again, check the vertical position of the chimney and the 2" (51 mm) minimum air space to combustibles (See ****Note**).

Next, slide roof flashing over extended chimney section that previously has been installed above the roof opening in Step 4. FTF8 flashings require flashing spacers. Slide flashing all the way down until the flashing base rests flat on the roof (Figure 27). Again, check the vertical position of the chimney and the 2" minimum air space to combustibles.

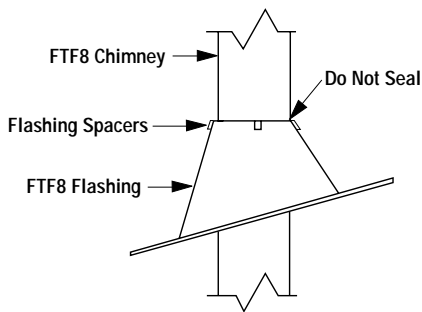

Figure 27

Note: Do not caulk or seal the ventilating openings.

Step 7. Secure flashing by nailing along the perimeter into roof using 8d nails. If shingled roof, slide upper end and sides of roof flashing under shingles (trim if necessary), seal the top and both sides of the flashing to the roof with roof caulking. Cover nail heads with roof caulking (Figure 28).

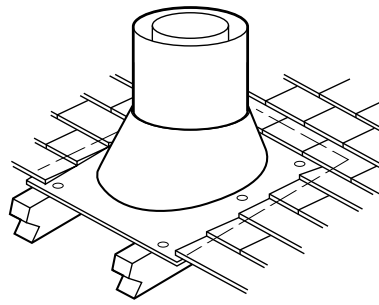

Figure 28

Step 8. Slide storm collar (ordered separately) over outer chimney, align with top surface of flashing, insert tab in slot, pull tight and bend tab back over slot. Seal storm collar to outer chimney with waterproof roof caulking around entire circumference of pipe. Also add extra roof caulking where storm collar meets flashing and to the tab/slot area to seal completely against water penetration (Figure 29). Check all joints very carefully to ensure no water intrusion can take place.

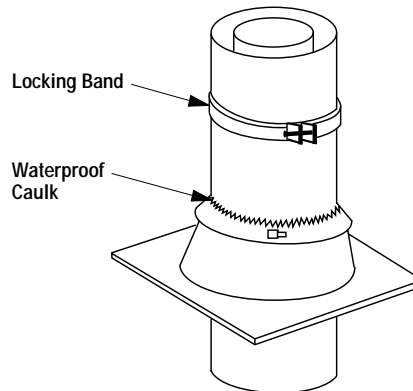

Figure 29

Step 9. Security Chimneys locking bands, Model FLB, may be required if the chimney extends too high above the roof flashing. As a general rule, if the chimney extends more than 6' above the roof flashing, the use of locking bands is advisable to strengthen the chimney assembly. Align the locking band at the chimney joint. Locking bands wrap around pipe joints equally covering the joints of both pipe sections. Use the nut provided and TIGHTEN snugly. Do not overtighten as this might damage the chimney section (refer to Figure 29).

**** Note:** 1" (25 mm) when installed with FTF10 in the U.S. only.

Note: If chimney extends more than 8' above roof surface, guy wires are also recommended. Use three (3) guy wires, attach to locking band assembly, extend and secure to roof in a triangular pattern (Figure 30). Guy wires are not supplied by the manufacturer.

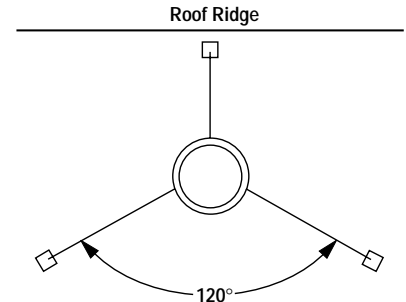

Figure 30

Step 10. Using a CTD Round Termination:

1. Hold the CTD over top of last chimney section (Figure 31).
2. Center inner slip section in inner flue pipe-slip down.
3. Center outer locking section over outer flue pipe. Push down until locking tabs are firmly engaged.
4. Pull up slightly on CTD to ensure locking joint has firmly engaged.

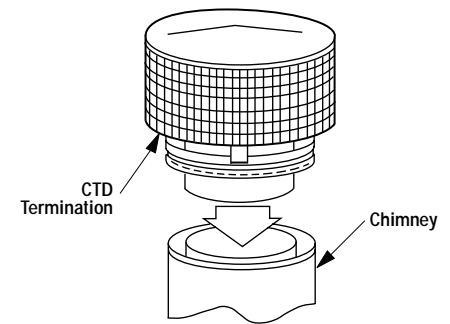

Figure 31

Using a FTF8/10-CTDT Chase Termination:

Refer to specific installation instructions included with the FTF8/10-CTDT chase termination for clearance and installation details.

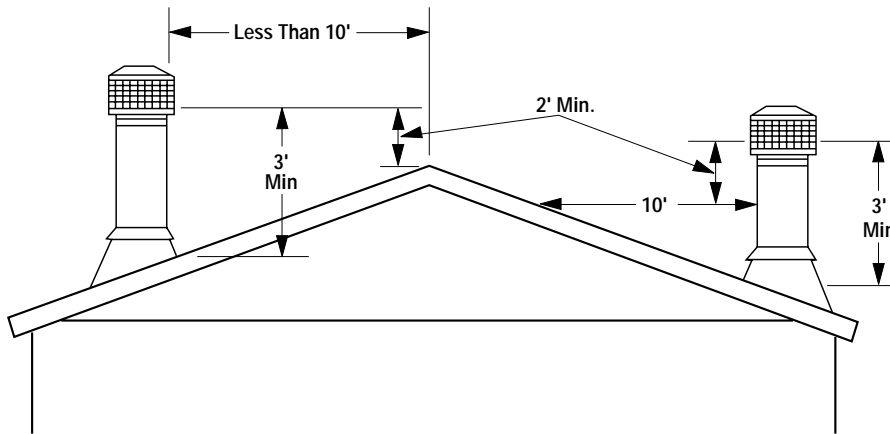

Figure 32

Using a FTF8/10-CT1 Chase Termination:

Refer to specific installation instructions included with FTF8/10-CT1 chase terminations for clearance and installation details.

Using a FTF8/10-CT2 Chase Termination:

Refer to specific installation instructions included with FTF8/10-CT2 chase terminations for clearance and installation details.

Note: It is recommended that all exterior exposed metal fireplace components; such as terminations, flashings, storm collars and/or flue be painted with a premium quality, high temperature, rust preventative paint designed for metal. This is especially important when installations are made in abnormally adverse or corrosive environments; such as near lakes, oceans or in areas with consistently high humidity conditions. Consult the paint manufacturers instructions for proper preparation and application.

TEN FOOT RULE SUMMARY

The minimum chimney height above the roof and/or to adjacent walls and buildings is specified by all major building codes.

If the horizontal distance from the peak of the roof is less than 10', the top of the chimney must be at least 2' above the peak of the roof.

If the horizontal distance from the chimney edge to the peak of the roof is more than 10' a chimney height reference point is established on the roof surface 10' horizontally from the chimney edge. The top of the chimney must be at least 2' above this reference point. In all cases, the chimney cannot be less than 3' above the roof at the edge of the chimney.

The 2' in 10' rule is necessary in the interest of safety but does not ensure smoke-free operation. Trees, buildings, adjoining roof lines, adverse wind conditions, etc., may require a taller chimney should the fireplace not draft properly (see Figure 32).

MULTIPLE TERMINATIONS

If more than one termination is located in the same chase or within the same general proximity, we suggest they should be separated in distance at least 24" horizontally from flue center to flue center and stacked or staggered vertically at least 18" apart, from the termination of one smoke exit to the termination of another smoke exit (Figure 33).

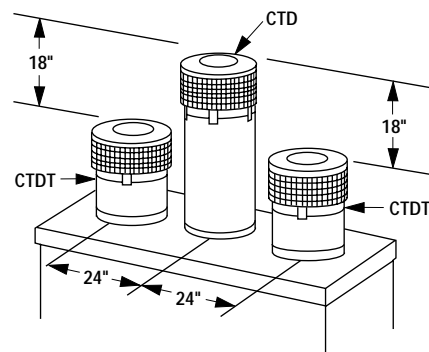

Figure 33

This suggestion is provided in the interest of better operation. If the terminations are located too close to each other, smoke may migrate from one flue into the other.

FTF8 AND FTF10 CHIMNEY COMPONENT CALCULATIONS

The minimum installed height of the completed fireplace systems is 15' 2" (4.67 m). The maximum height for all systems is 50' 0" (15.24 m). To determine the number of chimney sections and chimney components required, follow these steps:

1. Determine total vertical height of the fireplace installation. This dimension is the distance from the surface the fireplace sets on to the point where smoke exits from the termination.
2. Determine the number of chimney components required, except chimney sections. This would include firestop spacers, stabilizers, roof flashing, etc.
3. The effective heights of the components are:

The Fireplace	=	39-1/2" (1003 mm)
FTF8/FTF10-12	=	10-1/4" (260 mm)
FTF8/F10-18	=	16-1/4" (413 mm)
FTF8/F10-36	=	34-1/4" (870 mm)
FTF8-48	=	46-1/4" (1175 mm)
CTD Termination	=	4" (102 mm)
CT1 Termination	=	12" to 18" (305 mm to 457 mm)
CT2 Termination	=	15" to 23" (381 mm to 584 mm)
SS Starter Section	=	19-1/4" (489 mm)
S4 Stabilizer *	=	3" (76 mm)*

* Required for every 30' (9.1 m) of vertical chimney and/or 10' of offset chimney.

4. Determine amount of chimney height required by subtracting total combined height of all pre-selected components (fireplace and chimney components from total desired height.)

Reference Vertical Elevation Chart and determine the number of chimney sections (quantity and length) required.

SPECIAL OFFSET INSTRUCTIONS

To clear any overhead obstructions, you may offset your chimney system using Security's 30° offset and return elbows. Use two elbows — an offset elbow to initiate the offset and a return elbow to terminate it.

The offset and return elbows may be attached together, or a section or sections of chimney may be used between, but do not exceed 20' in total length between elbows. If sections of pipe exceed 10' between elbows, a chimney stabilizer must be used at the midpoint (Figure 34). The stabilizer support straps must be attached under tension (in shear) to structural framing members above. When two sets of elbows are used, the maximum combined length of chimney used between elbows cannot exceed 20' (Figure 35). **Example:** If $C_1 = 10'$ then C_2 cannot exceed 10'.

If an offset exceeds 6' in length, each chimney joint beyond the first 6' of offset to the return elbow, must be secured by a No. 8 x 1/2" sheet metal screw located at the underside of the joint (Figure 36).

A 1/8" diameter hole must be drilled in the chimney joint using a 1/8" diameter drill. Hole should be drilled in center of joint overlap (Figure 37). Be sure to drill only through the outer chimney casting. Do not puncture the inner flue.

Maximum offset of chimney system is 30°. Two offsets must not be assembled to form a 60° offset. However, two sets of offset and return elbows may be used on a single flue system, provided the total height of the system exceeds 25'.

Return elbow support straps must be securely attached under tension (in shear) to structural framing members above. Do not substitute a FTF8/10-30 offset elbow in place of a FTF8/10-E30 return elbow.

OFFSET CALCULATIONS

Step 1. Use Offset Chart to determine amount of horizontal offset (A) and height (B) for various chimney section assemblies.

Step 2. Use "Height of Chimney Only" column in The Vertical Elevation Chart to determine combinations of chimney used above return elbow to achieve desired heights. Reference Components Effective Height Chart in vertical elevation chart section.

Step 3. Use Elevation Chart as job estimator only. Add necessary firestop spacers and stabilizers as required. Firestop spacers must be used as shown in Figures 21 and 22 and stabilizers as shown in Figure 26.

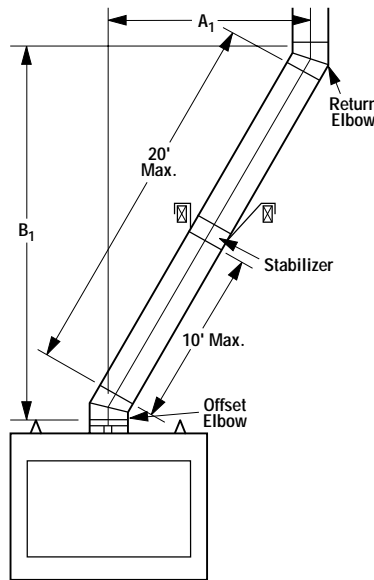

Figure 34

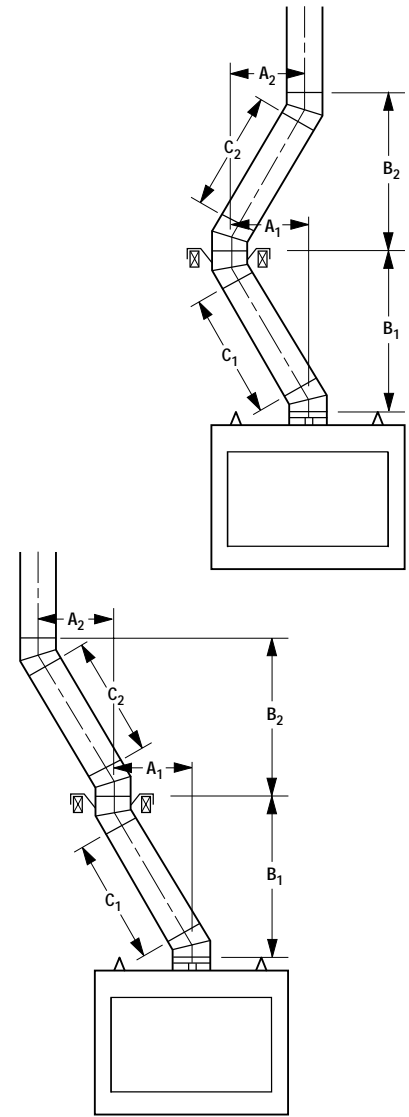

Figure 35

FTF8 VERTICAL ELEVATION CHART

Height Of Chimney Only		Number Of FTF8 Chimney Components						Height Of Chimney Only	Height Of Chimney Only		Number Of FTF8 Chimney Components						Height Of Chimney Only
Inches	Feet/Inches	12"	18"	24"	36"	48"	-S4	Meters	Inches	Feet/Inches	12"	18"	24"	36"	48"	-S4	Meters
10 ¼	0 10 ¼	1	0	0	0	0	-	0.26	247 ½	20 7 ½	0	1	0	0	5	-	6.29
16 ¼	1 4 ¼	0	1	0	0	0	-	0.41	253 ½	21 1 ½	0	0	1	0	5	-	6.44
22 ¼	1 10 ¼	0	0	1	0	0	-	0.57	257 ¾	21 5 ¾	1	1	0	0	5	-	6.55
26 ½	2 2 ½	1	1	0	0	0	-	0.67	263 ¾	21 11 ¾	1	0	1	0	5	-	6.70
32 ½	2 8 ½	1	0	1	0	0	-	0.83	269 ¾	22 5 ¾	0	1	1	0	5	-	6.85
34 ¼	2 10 ¼	0	0	0	1	0	-	0.87	275 ¾	22 11 ¾	1	0	0	1	5	-	7.00
38 ½	3 2 ½	0	1	1	0	0	-	0.98	277 ½	23 1 ½	0	0	0	0	6	-	7.05
44 ½	3 8 ½	1	0	0	1	0	-	1.13	281 ¾	23 5 ¾	0	1	0	1	5	-	7.16
46 ¼	3 10 ¼	0	0	0	0	1	-	1.17	287 ¾	23 11 ¾	1	0	0	0	6	-	7.31
50 ½	4 2 ½	0	1	0	1	0	-	1.28	293 ¾	24 5 ¾	0	1	0	0	6	-	7.46
56 ½	4 8 ½	1	0	0	0	1	-	1.44	299 ¾	24 11 ¾	0	0	1	0	6	-	7.61
62 ½	5 2 ½	0	1	0	0	1	-	1.59	304	25 4	1	1	0	0	6	-	7.72
68 ½	5 8 ½	0	0	1	0	1	-	1.74	310	25 10	1	0	1	0	6	-	7.87
72 ¾	6 ¾	1	1	0	0	1	-	1.85	316	26 4	0	1	1	0	6	-	8.03
78 ¾	6 6 ¾	1	0	1	0	1	-	2.00	322	26 10	1	0	0	1	6	-	8.18
84 ¾	7 ¾	0	1	1	0	1	-	2.15	323 ¾	26 11 ¾	0	0	0	0	7	-	8.22
90 ¾	7 6 ¾	1	0	0	1	1	-	2.31	328	27 4	0	1	0	1	6	-	8.33
92 ½	7 8 ½	0	0	0	0	2	-	2.35	334	27 10	1	0	0	0	7	-	8.48
96 ¾	8 ¾	0	1	0	1	1	-	2.46	340	28 4	0	1	0	0	7	-	8.64
102 ¾	8 6 ¾	1	0	0	0	2	-	2.61	346	28 10	0	0	1	0	7	-	8.79
108 ¾	9 ¾	0	1	0	0	2	-	2.76	350 ¼	29 2 ¼	1	1	0	0	7	-	8.90
114 ¾	9 6 ¾	0	0	1	0	2	-	2.91	356 ¼	29 8 ¼	1	0	1	0	7	-	9.05
119	9 11	1	1	0	0	2	-	3.02	365 ¼	30 5 ¼	0	1	1	0	7	1	9.28
125	10 5	1	0	1	0	2	-	3.18	371 ¼	30 11 ¼	1	0	0	1	7	1	9.43
131	10 11	0	1	1	0	2	-	3.33	373	31 1	0	0	0	0	8	1	9.47
137	11 5	1	0	0	1	2	-	3.48	377 ¼	31 5 ¼	0	1	0	1	7	1	9.58
138 ¾	11 6 ¾	0	0	0	0	3	-	3.52	383 ¼	31 11 ¼	1	0	0	0	8	1	9.73
143	11 11	0	1	0	1	2	-	3.63	389 ¼	32 5 ¼	0	1	0	0	8	1	9.89
149	12 5	1	0	0	0	3	-	3.78	395 ¼	32 11 ¼	0	0	1	0	8	1	10.04
155	12 11	0	1	0	0	3	-	3.94	399 ½	33 3 ½	1	1	0	0	8	1	10.15
161	13 5	0	0	1	0	3	-	4.09	405 ½	33 9 ½	1	0	1	0	8	1	10.30
165 ¼	13 9 ¼	1	1	0	0	3	-	4.20	411 ½	34 3 ½	0	1	1	0	8	1	10.45
171 ¼	14 3 ¼	1	0	1	0	3	-	4.35	417 ½	34 9 ½	1	0	0	1	8	1	10.60
177 ¼	14 9 ¼	0	1	1	0	3	-	4.50	419 ¼	34 11 ¼	0	0	0	0	9	1	10.65
183 ¼	15 3 ¼	1	0	0	1	3	-	4.65	423 ½	35 3 ½	0	1	0	1	8	1	10.76
185	15 5	0	0	0	0	4	-	4.70	429 ½	35 9 ½	1	0	0	0	9	1	10.91
189 ¼	15 9 ¼	0	1	0	1	3	-	4.81	435 ½	36 3 ½	0	1	0	0	9	1	11.06
195 ¼	16 3 ¼	1	0	0	0	4	-	4.96	441 ½	36 9 ½	0	0	1	0	9	1	11.21
201 ¼	16 9 ¼	0	1	0	0	4	-	5.11	445 ¾	37 1 ¾	1	1	0	0	9	1	11.32
207 ¼	17 3 ¼	0	0	1	0	4	-	5.26	451 ¾	37 7 ¾	1	0	1	0	9	1	11.47
211 ½	17 7 ½	1	1	0	0	4	-	5.37	457 ¾	38 1 ¾	0	1	1	0	9	1	11.63
217 ½	18 1 ½	1	0	1	0	4	-	5.52	463 ¾	38 7 ¾	1	0	0	1	9	1	11.78
223 ½	18 7 ½	0	1	1	0	4	-	5.68	465 ½	38 9 ½	0	0	0	0	10	1	11.82
229 ½	19 1 ½	1	0	0	1	4	-	5.83	469 ¾	39 1 ¾	0	1	0	1	9	1	11.93
231 ¼	19 3 ¼	0	0	0	0	5	-	5.87	475 ¾	39 7 ¾	1	0	0	0	10	1	12.08
235 ½	19 7 ½	0	1	0	1	4	-	5.98	481 ¾	40 1 ¾	0	1	0	0	10	1	12.24
241 ½	20 1 ½	1	0	0	0	5	-	6.13	486	40 6	1	0	1	1	9	1	12.34

FTF10 VERTICAL ELEVATION CHART

Height Of Chimney Only		Number Of FTF10 Chimney Lengths			Height Of Chimney Only		Height Of Chimney Only		Number Of FTF10 Chimney Lengths			Height Of Chimney Only	
Inches	Feet/Inches	12"	18"	36"	MM	M	Inches	Feet/Inches	12"	18"	36"	MM	M
11	0 11	1	0	0	279	0.28	461 1/2	38 5 1/2	0	1	13	11722	11.72
17	1 5	0	1	0	432	0.43	465 1/2	38 9 1/2	2	0	13	11824	11.82
21 1/4	1 9 1/4	2	0	0	540	0.54	471 1/2	39 3 1/2	1	1	13	11976	11.98
27 1/4	2 3 1/4	1	1	0	692	0.69	479 1/2	39 11 1/2	0	0	14	12179	12.18
33 1/4	2 9 1/4	0	2	0	845	0.85	489 1/2	40 9 1/2	1	0	14	12433	12.43
35	2 11	0	0	1	889	0.89	495 1/2	41 3 1/2	0	1	14	12586	12.59
37 1/4	3 1 1/4	2	1	0	946	0.95	499 3/4	41 7 3/4	2	0	14	12694	12.69
43 1/4	3 7 1/4	1	2	0	1099	1.10	505 3/4	42 1 3/4	1	1	14	12846	12.85
51 1/4	4 3 1/4	0	1	1	1302	1.30	513 1/2	42 9 1/2	0	0	15	13043	13.04
55 1/4	4 7 1/4	2	0	1	1403	1.40	523 3/4	43 7 3/4	1	0	15	13303	13.30
61 1/4	5 1 1/4	1	1	1	1556	1.56	529 3/4	44 1 3/4	0	1	15	13456	13.46
67 1/4	5 7 1/4	0	2	1	1708	1.71	534	44 6	2	0	15	13564	13.56
69 1/4	5 9 1/4	0	0	2	1759	1.76	540	45 0	1	1	15	13716	13.71
79 1/4	6 7 1/4	1	0	2	2013	2.01	547 3/4	45 7 3/4	0	0	16	13913	13.91
85 1/4	7 1 1/4	0	1	2	2165	2.17	558	46 6	1	0	16	14173	14.17
89 1/2	7 5 1/2	2	0	2	2273	2.27	564	47 0	0	1	16	14326	14.33
95 1/2	7 11 1/2	1	1	2	2426	2.43	568 1/4	47 4 1/4	2	0	16	14434	14.43
103 1/4	8 7 1/4	0	0	3	2622	2.62	574 1/4	47 10 1/4	1	1	16	14586	14.59
113 1/2	9 5 1/2	1	0	3	2883	2.88	582	48 6	0	0	17	14783	14.78
119 1/2	9 11 1/2	0	1	3	3035	3.03	592 1/4	49 4 1/4	1	0	17	15043	15.04
123 3/4	10 3 3/4	2	0	3	3143	3.14	598 1/4	49 10 1/4	0	1	17	15196	15.20
129 3/4	10 9 3/4	1	1	3	3296	3.30	602 1/4	50 2 1/4	2	0	17	15297	15.30
137 1/2	11 5 1/2	0	0	4	3493	3.49	608 1/4	50 8 1/4	1	1	17	15450	15.45
147 3/4	12 3 3/4	1	0	4	3753	3.75	616 1/4	51 4 1/4	0	0	18	15653	15.65
153 3/4	12 9 3/4	0	1	4	3905	4.91	626 1/4	52 2 1/4	1	0	18	15907	15.91
158	13 2	2	0	4	4013	4.01	632 1/4	52 8 1/4	0	1	18	16059	16.06
164	13 8	1	1	4	4166	4.17	636 1/2	53 0 1/2	2	0	18	16167	16.17
171 3/4	14 3 3/4	0	0	5	4362	4.36	642 1/2	53 6 1/2	1	1	18	16320	16.32
182	15 2	1	0	5	4623	4.62	650 1/4	54 2 1/2	0	0	19	16516	16.52
188	15 8	0	1	5	4775	4.78	660 1/2	55 0 1/2	1	0	19	16777	16.78
192	16 0	2	0	5	4877	4.88	666 1/2	55 6 1/2	0	1	19	16929	16.93
198	16 6	1	1	5	5029	5.03	670 3/4	55 10 3/4	2	0	19	17037	17.04
206	17 2	0	0	6	5232	5.23	676 3/4	56 4 3/4	1	1	19	17189	17.19
215 3/4	17 11 3/4	1	0	6	5480	5.48	684 1/2	57 0 1/2	0	0	20	17386	17.39
222	18 6	0	1	6	5639	5.64	694 3/4	57 10 3/4	1	0	20	17647	17.65
226 1/4	18 10 1/4	2	0	6	5747	5.75	700 3/4	58 4 3/4	0	1	20	17799	17.80
232 1/4	19 4 1/4	1	1	6	5899	5.90	705	58 9	2	0	20	17907	17.91
240	20 0	0	0	7	6096	6.10	711	59 3	1	1	20	18059	18.06
250 1/4	20 10 1/4	1	0	7	6356	6.36	718 3/4	59 10 3/4	0	0	21	18256	18.26
256 1/4	21 4 1/4	0	1	7	6509	6.51	729	60 9	1	0	21	18517	18.52
260 1/2	21 8 1/2	2	0	7	6617	6.62	735	61 3	0	1	21	18669	18.67
266 1/2	22 2 1/2	1	1	7	6769	6.77	739	61 7	2	0	21	18771	18.77
274 1/4	22 10 1/4	0	0	8	6966	6.97	745	62 1	1	1	21	18923	18.92
284 1/2	23 8 1/2	1	0	8	7226	7.23	753	62 9	0	0	22	19126	19.13
290 1/2	24 2 1/2	0	1	8	7379	7.38	763	63 7	1	0	22	19380	19.38
294 3/4	24 6 3/4	2	0	8	7487	7.49	769	64 1	0	1	22	19533	19.53
300 3/4	25 0 3/4	1	1	8	7639	7.64	773 1/4	64 5 1/4	2	0	22	19641	19.64
308 1/2	25 8 1/2	0	0	9	7836	7.84	779 1/4	64 11 1/4	1	1	22	19793	19.79
318 3/4	26 8 3/4	1	0	9	8096	8.10	787	65 7	0	0	23	19990	19.99
324 3/4	27 0 3/4	0	1	9	8249	8.25	797 1/4	66 5 1/4	1	0	23	20250	20.25
328 3/4	27 4 3/4	2	0	9	8350	8.35	803 1/4	66 11 1/4	0	1	23	20403	20.40
334 3/4	27 10 3/4	1	1	9	8503	8.50	807 1/2	67 3 1/2	2	0	23	20511	20.51
342 3/4	28 6 3/4	0	0	10	8706	8.71	813 1/2	67 9 1/2	1	1	23	20663	20.66
352 3/4	29 4 3/4	1	0	10	8960	8.96	821 1/4	68 5 1/4	0	0	24	20860	20.86
358 3/4	29 10 3/4	0	1	10	9112	9.11	831 1/2	69 3 1/2	1	0	24	21120	21.12
363	30 3	2	0	10	9220	9.22	837 1/2	69 9 1/2	0	1	24	21273	21.27
369	30 9	1	1	10	9373	9.37	841 3/4	70 1 3/4	2	0	24	21380	21.38
376 3/4	31 4 3/4	0	0	11	9569	9.57	847 3/4	70 7 3/4	1	1	24	21533	21.53
387	32 3	1	0	11	9829	9.83	855 1/2	71 3 1/2	0	0	25	21730	21.73
393	32 9	0	1	11	9982	9.98	865 3/4	72 1 3/4	1	0	25	21990	21.99
397 1/4	33 1 1/4	2	0	11	10090	10.09	871 3/4	72 6 3/4	0	1	25	22142	22.14
403 1/4	33 7 1/4	1	1	11	10243	10.24	875 3/4	72 11 3/4	2	0	25	22244	22.24
411	34 3	0	0	12	10439	10.44	881 3/4	73 5 3/4	1	1	25	22396	22.40
421 1/4	35 1 1/4	1	0	12	10700	10.70	889 3/4	74 1 3/4	0	0	26	22600	22.60
427 1/4	35 7 1/4	0	1	12	10852	10.85	899 3/4	74 11 3/4	1	0	26	22854	22.85
431 1/2	35 11 1/2	2	0	12	10960	10.96	905 3/4	75 5 3/4	0	1	26	23006	23.01
437 1/2	36 5 1/2	1	1	12	11113	11.11	910	75 10	2	0	26	23114	23.11
445 1/4	37 1 1/4	0	0	13	11309	11.31	916	76 4	1	1	26	23266	23.27
455 1/2	37 11 1/2	1	0	13	11570	11.57	924	77 0	0	0	27	23470	23.47

FTF8 OFFSET ELEVATION CHART (With FTF8-SS Starter Section)

A Offset (Inches)	B Height (Inches)	FTF10/8-ES30 Offset/Return Elbow Set	FTF8-SS Starter Section	FTF8-S4 Stabilizer	Number of FTF8 Chimney Sections				A Offset (mm)	B Height (mm)
					12"	18"	36"	48"		
14	32 ½	1	1	0	0	0	0	0	356	826
19	41 ¼	1	1	0	1	0	0	0	483	1048
22	46 ½	1	1	0	0	1	0	0	559	1181
24 ¼	50 ¼	1	1	0	2	0	0	0	616	1276
27 ¼	55 ¼	1	1	0	1	1	0	0	692	1403
30 ¼	60 ½	1	1	0	0	2	0	0	768	1537
31	62	1	1	0	0	0	1	0	787	1575
32 ¼	64 ¼	1	1	0	2	1	0	0	819	1632
35 ¼	69 ¼	1	1	0	1	2	0	0	895	1759
36 ¼	71	1	1	0	1	0	1	0	921	1803
37	72 ½	1	1	0	0	0	0	1	940	1842
38 ¼	74 ½	1	1	0	0	3	0	0	972	1892
39 ¼	76	1	1	0	0	1	1	0	997	1930
41 ½	79 ¾	1	1	0	2	0	1	0	1048	2026
42 ¼	81 ¼	1	1	0	1	0	0	1	1073	2064
44 ¼	85	1	1	0	1	1	1	0	1124	2159
45 ¼	86 ½	1	1	0	0	1	0	1	1149	2197
47 ¼	90	1	1	0	0	2	1	0	1200	2286
48 ¼	91 ¾	1	1	0	0	0	2	0	1226	2330
49 ¼	93 ¾	1	1	0	2	1	1	0	1251	2381
51 ½	97 ¼	1	1	0	1	4	0	0	1308	2470
53 ¼	100 ½	1	1	0	1	0	2	0	1353	2553
54 ¼	102	1	1	0	0	0	1	1	1378	2591
55 ½	104 ¼	1	1	0	0	3	1	0	1403	2648
56 ¼	105 ¾	1	1	0	0	1	2	0	1429	2686
58 ¼	109 ¼	1	1	0	2	0	2	0	1480	2775
59 ¼	111	1	1	0	1	0	1	1	1505	2819
60 ¼	112 ½	1	1	0	0	0	0	2	1530	2858
61 ¼	114 ½	1	1	1	1	1	2	0	1556	2908
65 ¾	122 ¼	1	1	1	0	2	2	0	1670	3105
66 ¾	124	1	1	1	1	0	0	2	1695	3150
68	126	1	1	1	2	1	2	0	1727	3200
69 ¾	129	1	1	1	0	1	0	2	1772	3277
71 ¾	132 ¾	1	1	1	1	0	3	0	1822	3372
74 ¾	138	1	1	1	0	1	3	0	1899	3505
77	141 ½	1	1	1	2	0	3	0	1956	3594
78 ¾	144 ¾	1	1	1	0	0	1	2	2000	3677
80	146 ¾	1	1	1	1	1	3	0	2032	3727
83	152	1	1	1	0	2	3	0	2108	3861
84 ¾	155	1	1	1	0	0	0	3	2153	3937
89	162 ¼	1	1	1	1	0	4	0	2261	4121
89 ¾	164	1	1	1	1	0	0	3	2280	4166
92	167 ½	1	1	1	0	1	4	0	2337	4255
92 ¾	169	1	1	1	0	1	0	3	2356	4293

FTF10 OFFSET ELEVATION CHART

A Offset (Inches)	B Height (Inches)	FTF10-ES30 Offset/Return Elbow Set	FTF10-S4 Stabilizer	Number of FTF10 Chimney Sections			A Offset (mm)	B Height (mm)
				12"	18"	36"		
4	15 ¾	1	0	0	0	0	102	400
9	24 ½	1	0	1	0	0	229	622
12	29 ¾	1	0	0	1	0	305	756
14 ¼	33 ½	1	0	2	0	0	362	851
17 ¼	38 ½	1	0	1	1	0	438	978
20 ¼	43 ¾	1	0	0	2	0	514	1111
21	45 ¼	1	0	0	0	1	533	1149
22 ¼	47 ½	1	0	2	1	0	565	1207
25 ¼	52 ½	1	0	1	2	0	641	1334
26 ¼	54 ¼	1	0	1	0	1	667	1378
28 ¼	57 ¾	1	0	0	3	0	718	1467
29 ¼	59 ¼	1	0	0	1	1	743	1505
31 ¼	63	1	0	2	0	1	794	1600
32 ½	65	1	0	4	1	0	826	1651
34 ¼	68 ¼	1	0	1	1	1	870	1734
36 ¼	71 ¾	1	0	3	0	1	921	1822
37 ¼	73 ¼	1	0	0	2	1	946	1861
38 ¼	75	1	0	0	0	2	972	1905
39 ¼	77	1	0	2	1	1	997	1956
41 ½	80 ½	1	0	1	4	0	1054	2045
43 ¼	83 ¾	1	0	1	0	2	1099	2127
44 ½	85 ¾	1	0	3	1	1	1130	2178
45 ¼	87 ½	1	0	0	3	1	1149	2223
46 ¼	89	1	0	0	1	2	1175	2261
48 ¼	91 ½	1	0	2	0	2	1226	2324
49 ½	94 ½	1	0	1	5	0	1257	2400
51 ¼	97 ¾	1	0	1	1	2	1302	2483
54 ¼	103	1	0	0	2	2	1378	2616
55 ¼	104 ½	1	0	0	0	3	1403	2654
56 ½	106 ½	1	0	2	1	2	1435	2705
59 ½	111 ¾	1	0	1	2	2	1511	2838
61 ¾	116	1	1	1	0	3	1568	2946
64 ¾	121 ¼	1	1	0	1	3	1645	3080
67	124 ¾	1	1	2	0	3	1702	3169
69	127 ¾	1	1	1	3	2	1753	3245
70	130	1	1	1	1	3	1778	3302
73	135 ¼	1	1	0	2	3	1854	3435
75	138 ¾	1	1	2	1	3	1905	3524
79	145 ½	1	1	1	0	4	2007	3696
80 ¼	147 ½	1	1	3	1	3	2038	3747
82	150 ¾	1	1	0	1	4	2083	3829
87	159 ½	1	1	1	1	4	2210	4051

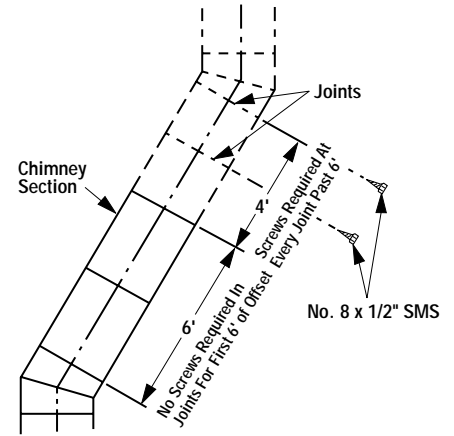

Figure 36

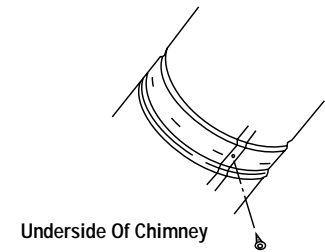
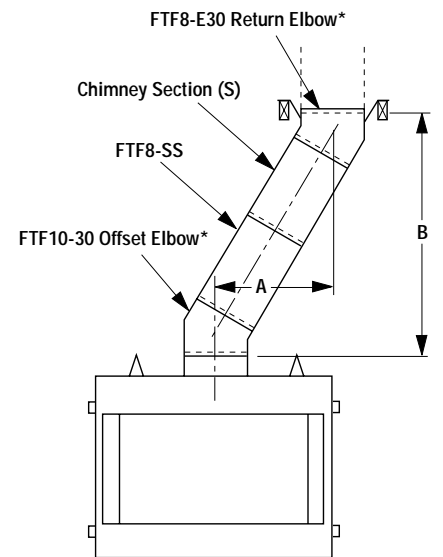

Figure 37



*Part of Offset/Return Package Model FTF10/8-ES30

Figure 38

INSTALLING OFFSETS

First, review the Offset Elevation Chart and *Figure 38* for reference.

Step 1. Determine the offset distance where chimney is to pass through the first ceiling-dimension "A." To find this point on your ceiling, first determine the center point for a vertical chimney following the instructions for vertical installation.

Measure height to the ceiling from the top of fireplace-dimension "B." Use the appropriate Offset Elevation Chart to find dimension "A." Mark point where you will drive your nail to show the center point for your offset ceiling cut.

Step 2. Proceed by using the Straight Up Installation Instructions for cutting and framing ceiling and roof openings.

Note: See *Framing and Dimension Chart* for the sizes of the ceiling and roof openings. The size of the roof opening varies with the degree of pitch of the roof.

Offset Elbow Assembly

Offset elbows install the same as chimney sections. First, snap the inner section INTO the preceding inner section of flue. Check connection by pulling up slightly to ensure a tight fit. Next, the outer sections snap lock OVER the preceding outer section of chimney. Again, check outer section by pulling up slightly to ensure proper connection is made.

Return Elbow Assembly

Return elbows install the same way as round terminations and stabilizers:

Step 1. Hold return elbow over top of last chimney section.

Step 2. Center inner slip section into inner flue pipe-slip down.

Step 3. Center outer-locking section over outer chimney pipe. Push down until locking joint has firmly engaged.

Step 4. Pull up slightly on return elbow to ensure locking joint has firmly engaged.

Step 5. Secure support straps to framing members by nailing under tension in sheer (*Figure 39*).

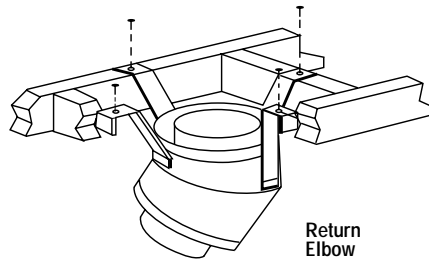

Figure 39

Note: The return elbow assembly performs the same function as a stabilizer. Consider this when determining the need for a stabilizer.

Note: Do not apply excessive pressure to any subsequent chimney section following return elbow assembly when installing. Ensure that each subsequent chimney section is securely attached by testing as noted above.

Combustion Air Kits

These appliances are equipped with an outside (make-up) air door and integral actuator arm. If the appliance is to be installed with an outside air vent system, use only Models FAOK-4 or FAOK-4LD Combustion Air Kits. These kits come complete with detailed installation instructions and all components necessary in completing a combustion air vent system.

After completing the installation of the optional combustion air vent system the actuator arm must be put in service and tested to ensure proper operation before completing any enclosure around the firebox. Failure to do so may result in extensive and costly rework.

The control lever that operates the outside combustion air valve has been pre-installed on your fireplace. A coverplate has been mounted over this control lever only if the outside air kit has not been attached. The control lever is located on the closed end of the fireplace opening behind the screen. To open the air damper, turn the lever handle 1/2 turn counter clockwise (or until lever can be moved upward), then retighten at desired open position. To close damper, reverse procedure (*see Figure 40*).

Operate the actuator through several cycles including the "lock position." Ensuring proper operation and freedom of movement. Return the actuator arm to the locked position.

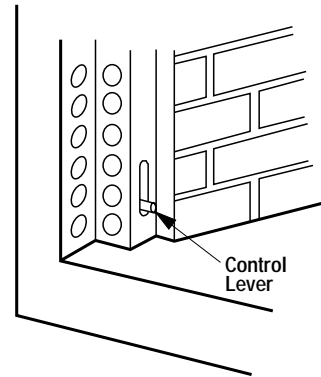

Figure 40

Gas Line Connection

Install a 1/2" (13 mm) gas supply line through fireplace wall for connection to a decorative gas appliance inside the firebox. Outside, the gas supply line must connect to a gas shut-off valve usually recessed flush into the wall or floor. The valve should be controlled by a removable valve key for safety.

CAUTION: PLUMBING CONNECTIONS SHOULD ONLY BE PERFORMED BY A QUALIFIED, LICENSED PLUMBER. MAIN GAS SUPPLY MUST BE OFF WHEN PLUMBING GAS LINE TO FIREPLACE OR PERFORMING SERVICE.

Always plumb gas line installation per local codes. Check all connections and test for gas leaks, using a gas leak test solution (also referred to as bubble leak solution).

Note: Using a soapy water solution (50% dish soap, 50% water) is an effective leak test solution but it is not recommended, because the soap residue that is left on the pipes/fittings can result in corrosion over time. **Never use an open flame to check for leaks.**

This provision is intended for connection to a decorative gas appliance incorporating an automatic shut-off device and complying with the Standard for Decorative Gas Appliances for installation in vented fireplaces, ANSI Z21.60 (1991) or American Gas Association draft requirements for Gas-Fired Log Lighters for Wood Burning Fireplaces, Draft No. 4 dated August, 1993. Install in accordance with the National Fuel Gas Code, ANSI Z223.1. This complies with the revised U.L. 127 standard.

Glass Doors

If glass doors are to be installed on these fireplaces, refer to specific installation instructions packed with the glass doors. Use only the doors that are listed for use with these fireplaces. Use of other non-listed glass door on these fireplaces may constitute a potential fire hazard and is not recommended.

CAUTION: CERTAIN GLASS DOORS OVERLAP THE BLACK METAL FACING OF THE FIREPLACE. IF THE FIREPLACE HAS BEEN FACED WITH NONCOMBUSTIBLE MATERIALS, THERE MIGHT NOT BE SUFFICIENT CLEARANCE TO INSTALL THE GLASS DOORS OF YOUR CHOICE. ENSURE ADEQUATE CLEARANCE IS MAINTAINED AT ALL TIMES SO AS NOT TO INTERFERE WITH THE INSTALLATION AND OPERATION OF GLASS DOORS.

COLD CLIMATE INSULATION

If you live in a cold climate, it is especially important to seal all cracks around the fireplace opening with noncombustible material and wherever cold air could enter the room. Surrounding materials must be caulked where it meets the black metal facing of the fireplace to avoid cold air intrusion. Use noncombustible caulking material only on fireplace facing to seal. Also, the outside air inlet duct should be wrapped with noncombustible insulation to minimize the formation of condensation. Do not place insulation materials on top of fireplace or against chimney sections.

Note: A 2" air space must be preserved for all combustible materials extending for any continuous length adjacent to the chimney.

It is especially important to insulate between the studs of an outside chase cavity and under the floor if the floor is above ground level. Do not place insulation directly against the fireplace or chimney system.

FIREPLACE FINISHES Mantels and Trim

It is sometimes best to frame your fireplace after it is positioned and the chimney is installed. Frame enclosure for chimney and fireplace with 2 x 4's (or heavier) lumber.

Note: The header may rest on the two (2) metal top spacers on top of the unit but the header must not be notched to fit around the spacers.

Note: Only non-combustible wall finishing materials are allowed on the front top of the unit, from the top edge of spacers down. (See Figures 41 and 42).

These fireplaces may sit directly on a combustible surface. A 2" air space is required between combustible framing and the chimney. A 1" air space is required between combustible framing and fireplace outer wrapper. In Canada, the minimum height for a combustible mantel is 18" (457 mm) above the fireplace opening. **Figure 41** shows typical Canadian installations. For installations other than Canada, combustible mantels and trim may be installed 12" above the fireplace opening as per NFPA 211, Section 7-2.3.3. and **Figure 42**. If a mantel is of a noncombustible material, it is exempt from these requirements as long as it does not interfere with the installation or operation of glass doors.

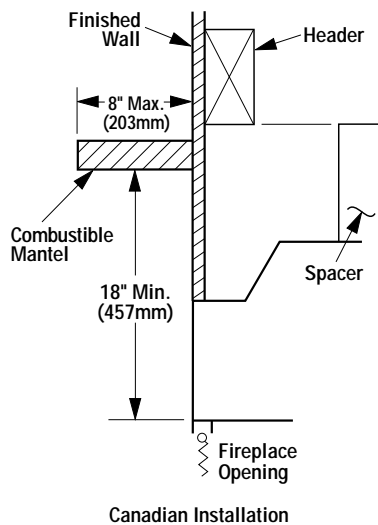
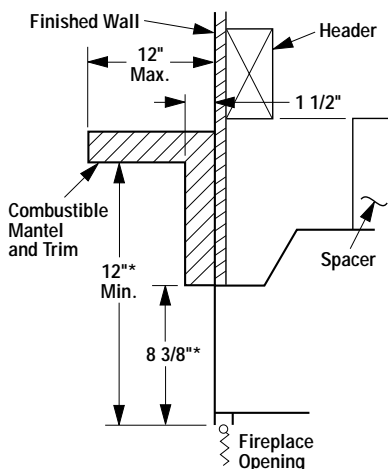

Figure 41



*Both Of These Dimensions Must Be At Least 18" When An Unvented Gas Log Set Rated At 26,000 BTU Or Higher Is Used. (Maximum 40,000 BTU)

Typical Installation

Figure 42

Hearth Extensions and Wall Shields

A hearth extension must be installed with all fireplaces. It is to protect the combustible floor in front of the fireplace from both radiant heat and sparks. The hearth extension must extend 8" beyond both sides of the fireplace opening and 16" beyond the front (see **Figure 43**). Use a hearth extension constructed of a durable noncombustible material having an equal or better (lower k value) insulating value of $k = .84 \text{ BTU IN/FT}^2 \text{ HR } ^\circ\text{F}$ or a thermal resistance that equals or exceeds $r = 1.19 \text{ HR } ^\circ\text{F FT}^2/\text{BTU IN}$. With these values, determine the minimum thickness/material required using the formula and **Page 19**.

Note: Any noncombustible material whose k value is less than .84 or whose r value is more than 1.19 is acceptable.

If the fireplace is installed on a combustible floor, use the metal safety strips (provided) on the floor extending half under the fireplace and half under the hearth extension (refer to **Figures 6 & 7**).

A wall shield is required where a continuous perpendicular side wall is within 12" of the fireplace opening (**Figure 44**). Use a 40" W x 40" H wall shield constructed of a durable, noncombustible material having an equal or better (lower k value) insulating value than $k = .84 \text{ BTU IN/FT}^2 \text{ HR } ^\circ\text{F}$. At no time may a perpendicular side wall be located closer than 8" from the fireplace opening. See **Figure 46**.

If fireplace is installed diagonally across a 90° corner; no wall shields are required.

Hearth Extension Dimensions

A	20" (508 mm)
B	38" (965 mm)
C	8" (203 mm)
D	20" (508 mm)
E	12" (305 mm)

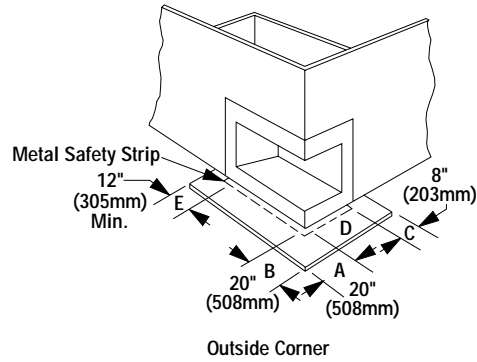

Figure 43

Methods of Determining Hearth Extension and Wall Shield

Equivalents - To determine the thickness required for the alternate material when either the "k" value or "r" value is known, use either the k formula or r formula.

Example: If Micore 160 is to be used for the hearth extension fireplace, how thick must this material be?

k_M = k value per inch of **alternate** material
 r_M = r value per inch of **alternate** material
 T_M = minimum thickness required for **alternate** material
 T_S = standard thickness of the **alternate** material

k_L = k value per inch of **listed** material
 r_L = r value per inch of **listed** material
 T_L = minimum thickness of **listed** material

Note: An asterix "*" indicates, it is a value taken from **Table 1**.
Using the k formula:

Minimum thickness of alternate material (T_M) = $\frac{\text{k-value (per Inch) of alternate material } (k_M)}{\text{k-value (per inch) of listed material } (k_L)} \times \text{Specified min. thickness of listed material } (T_L)$

$$T_M \text{ (inches)} = \frac{k_M}{*.84} \times T_L$$

$$T_M \text{ (inches)} = \frac{*.35}{*.84} \times 1"$$

$$.416 \text{ (inches)} = .416 \times 1"$$

Answer - The minimum required thickness of the Micore 160 is .417", therefore round up to nearest standard thickness available which is 1/2".

Using the r formula:

Minimum thickness of alternate material = $\frac{\text{r-value (per Inch) of listed material } (r_L)}{\text{r-value (per inch) of alternate material } (r_M)} \times \text{Specified min. thickness of listed material } (T_L)$

$$T_M \text{ (inches)} = \frac{r_L}{r_M} \times T_L$$

$$T_M \text{ (inches)} = \frac{*1.19}{*2.86} \times 1"$$

$$.416 \text{ (inches)} = .416 \times 1"$$

Answer - The minimum required thickness of the Micore 160 is .417", therefore round up to nearest standard thickness available which is 1/2".

Listed Material			
	k (per inch)	r (per inch)	Listed Min. Thickness
Listed Material	.84 k_L	1.19 r_L	1" T_L
** Approved Alternate Materials for Floor/Hearth Protection			
Alternative Materials	Thermal Values		Minimum Thickness (rounded to nearest 1/8 inch)
	k (per inch) k_M	r (per inch) r_M	Min. Thickness T_M
Kaowool M Board	.47	2.13	.56" (1/2")
Micore 160™ U.S. Gypsum	.35	2.86	.42" (3/8")
Micore 300™ U.S. Gypsum	.46	2.17	.55" (1/2")
Durock™ Cement Board U.S. Gypsum	1.92	.52	2.29" (2-1/4")
Hardibacker™	1.95	.513	2.32" (2-3/8")
Hardibacker 500™	2.30	.435	2.74" (2-3/4")
Cultured Stone Hearth-stone™	2.82	.355	3.36" (3-3/8")
Wonderboard	3.23	.31	3.85" (3-7/8")
Super Firetemp M Johns-Manville	.61	1.64	.73" (3/4")
Super Firetemp L Johns-Manville	.54	1.85	.64" (5/8")
Face brick	9.00	.111	10.71" (10-3/4")
Common brick	5.00	.20	5.95" (6")
Cement mortar	5.00	.20	5.95" (6")
Ceramic tile	12.5	.08	14.88" (14-7/8")
Marble	11	.09	13.10" (13-1/8")

Table 1

** If the hearth extension material(s) that is intended to be used is NOT listed on Table 1, the material can still be used if the material(s) is noncombustible. However, the manufacturer of the material must provide either the listed k-value per inch or r-value with listed thickness so that the minimum thickness required for the hearth can be calculated (per instructions on this Page and/or as specified in the NFI Certification manuals).

Note: Also see NFI (National Fireplace Institute) Certification Manuals showing other acceptable calculation methods and acceptable alternate materials which can be used.

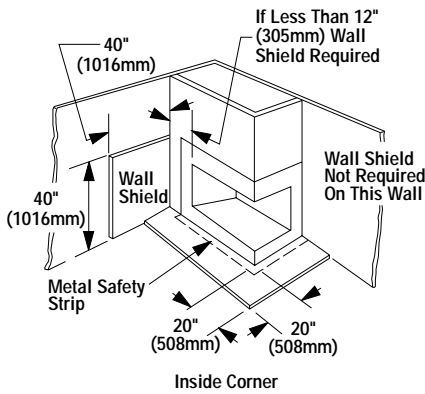

Figure 44

Calculating Minimum Thickness if Multiple Materials are Used

At times it is important to know what combination of materials are acceptable for use as floor protection. The "R values" are used to determine acceptable combinations of materials because "R values" are additive where r and k values are not.

"R value" = $1/k = "r" \times \text{thickness of material used}$

Example: Given that the required "R value" for a suitable floor protector used must be equal to or greater than:

$$"R" = r_L \times T_L = 1.19 \times 1" = 1.19."$$

If it is desired to elevate a marble hearth extension to a level of 5" or more above the floor surface. What combination of noncombustible materials can be used to accomplish this?

If common brick is used so that the 3 1/2" dimension is the height, "R" for the common brick becomes:

brick

$$"R"_{M} = r_{M} \times T_{S} = 0.20 \times 3\ 1/2" = .70$$

Using 1/2" of mortar to set the brick, "R" for the mortar is calculated as follows:

mortar

$$"R"_{M} = r_{M} \times T_{S} = 0.20 \times 1/2" = .10$$

Next, a 3/4" marble slab set in 1/2" mortar covers the brick, "R" for the marble and mortar becomes:

marble

$$"R"_{M} = r_{M} \times T_{S} = 0.05 \times 3/4" = .038$$

mortar

$$"R"_{M} = r_{M} \times T_{S} = 0.20 \times 1/2" = .10$$

The sum of all "R values" is: $.70 + .10 + .038 + .10 = .938$

This would NOT be an acceptable combination of material for the hearth extension since the total calculated "R value" of the materials used is under the required "R value" of 1.19. An additional layer of insulating materials must be used.

Note: Also see NFI Certification Manuals for expanded explanation on calculating "R values" when multiple materials are used.

WARNING: THE CRACK BETWEEN THE FIREPLACE AND THE HEARTH EXTENSION MUST BE SEALED WITH A NON-COMBUSTIBLE MATERIAL.

WARNING: WHEN INSTALLING HEARTH EXTENSION IN FRONT OF A NON-CIRCULATING FIREPLACE MODEL, THE FIREPLACE MUST BE RAISED IF HEIGHT OF HEARTH EXTENSION EXCEEDS 7" ABOVE THE BOTTOM OF FIREPLACE (FIGURE 45).

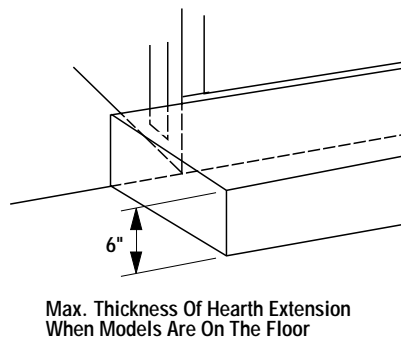

Figure 45

Secure the hearth extension to the floor to prevent possible shifting.

FINISH TO YOUR TASTE

There are a wide variety of "finished looks" for these fireplaces, from formal wall decor with elaborate mantels to rustic wood paneling or warm brick facings.

Only noncombustible materials like stone, tile, brick, etc., may overlap the black front facing. Do not extend these materials beyond the black facing and into the firebox area. Be sure not to interfere with the installation and operation of glass doors or block the upper or lower grilles. Seal all joints between the black facing and wall surrounds to prevent air intrusion. Use non-combustible caulking material only to seal the black metal facing to the surround material on the finished wall.

Combustible materials may project beyond the sides of the fireplace opening as long as they are kept within the shaded areas illustrated in Figure 46.

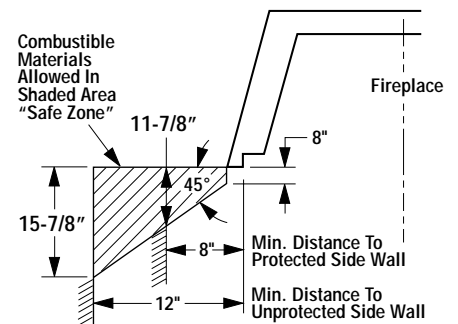

Figure 46

Model	Part Number	Weight
CR-3835R	P/N 015014	210 lbs.
CR-3835L	P/N 015013	210 lbs.

INSTALLATION COMPONENTS

The following items are available for use in the installation of this appliance.



	63L10	FTF8-12
	63L13	FTF8-18
	63L14	FTF8-36
	63L15	FTF8-48
	63L16	FTF10-12
	63L17	FTF10-18
Chimney Section	63L18	FTF10-36
<hr/>		
	62L92	FTF8-18C
	62L93	FTF8-36C
Canadian	62L94	FTF10-18C
Outside Chimney	62L95	FTF10-36C

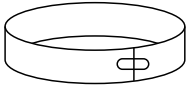

Locking Band	63L60	FLB
--------------	-------	-----

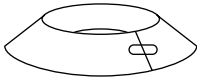

Storm Collar	63L59	FSC
--------------	-------	-----

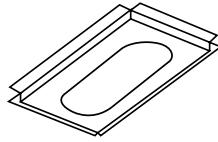

	63L30	F8FS30
	63L32	F8FS30-2
Firestop Spacer (30°)	63L37	F10FS30-2

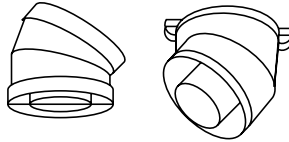

	63L22	FTF8-ES30
Offset/ Return	63L23	FTF10-ES30
Package (30°)	22154	FTF10/8-ES30

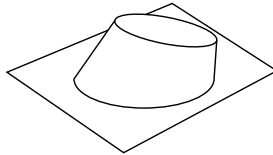

	63L38	F8F6
	63L39	F8F12
	63L40	F10F6
Flashing	63L41	F10F12

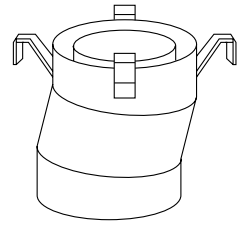

Combination	63L28	FTF8-OR15
Offset/Return Elbow	63L34	FTF10-OR15



Starter Section	8345	FTF8-SS
-----------------	------	---------

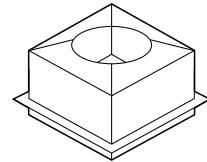

Attic Shield Assembly		
Firestop Spacer	63L67	FTF8-FSAS
Canada Only	63L68	FTF10-FSAS

INSTALLATION COMPONENTS

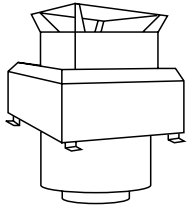

Chase Termination (Square) 63L51 FTF8-CT2
63L52 FTF10-CT2

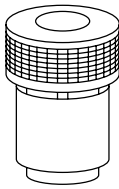

Chase Termination (Round) 63L45 FTF8-CTD
63L46 FTF10-CTD



Chase Termination 96L20 FTF8-CTT
96L21 FTF10-CTT

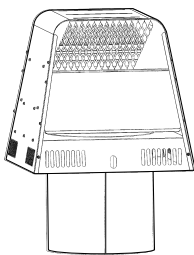

Arch Type Termination 96L22 FTF8-ATT
96L23 FTF10-ATT

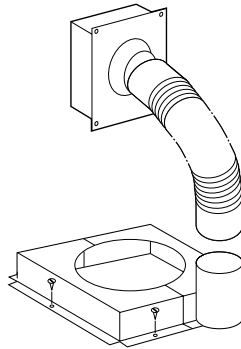

Cold Climate Kit 63L63 FTF10-CCK1-LD

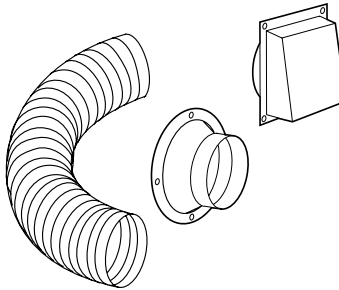

Outside Combustion Air Kits
(with duct) 81L87 FOAK
(without duct) 81L88 FOAK-LD

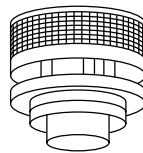

Round Termination 63L42 FTF8-CTD
63L43 FTF10-CTD

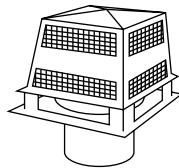

Chase Termination (Square) 63L48 FTF8-CT1
63L49 FTF10-CT1

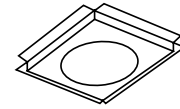

Firestop Spacer (Flat) 63L29 F8FS
63L31 F8FS-2
63L36 F10FS-2

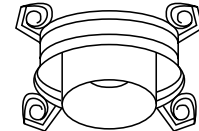

Stabilizer 63L25 FTF8-S4
63L26 FTF10-S4

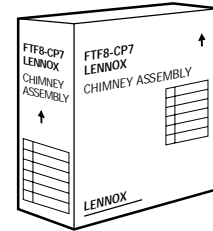

Contains:
3 FTF8-36
1 F8FS
1 F8F6
1 FTF8-CTD

Chimney Pack Conventional 63L70 FTF8-CP7

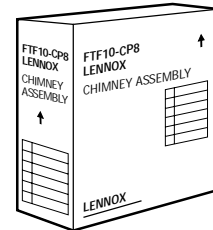

Contains:
4 FTF10-36
1 F10FS
1 F10F6
1 FTF10-CTD

Chimney Pack Conventional 63L71 FTF10-CP8

NOTES:

The manufacturer reserves the right to make changes at any time, without notice, in design, materials, specifications, prices and also to discontinue colors, styles and products. Consult your local distributor for fireplace code information.



HEARTH PRODUCTS

1110 West Taft Avenue
Orange, CA 92865

Printed in U.S.A. © 2007 by LENNOX HEARTH PRODUCTS
P/N 850,048M REV. A 03/2008