



**HEARTH PRODUCTS**

# INSTALLATION INSTRUCTIONS

## ELITE SERIES

38" & 43" Wood Burning Fireplaces  
P/N 850,003M REV. F 05/2006

### MODELS

- |                   |                   |
|-------------------|-------------------|
| <i>LBR-3824</i>   | <i>LBC-3824</i>   |
| <i>LBR-3824-H</i> | <i>LBC-3824-H</i> |
| <i>LBR-4324</i>   | <i>LBC-4324</i>   |
| <i>LBR-4324-H</i> | <i>LBC-4324-H</i> |

This installation manual will enable you to obtain a safe, efficient and dependable installation of your fireplace system. Please read and understand these instructions before beginning your installation.

Do not alter or modify the fireplace or its components under any circumstances. Any modification or alteration of the fireplace system, including but not limited to the fireplace, chimney components and accessories, may void the warranty, listings and approvals of this system and could result in an unsafe and potentially dangerous installation.

**IMPORTANT! TO ASSURE PROPER ALIGNMENT OF GLASS DOORS:  
INSTALL THIS FIREPLACE IN A SQUARE AND PLUMB CONDITION,  
USING SHIMS AS NECESSARY AT SIDES AND/OR BOTTOM.**

### RETAIN THESE INSTRUCTIONS FOR FUTURE REFERENCE

NATIONAL  
FIREPLACE  
INSTITUTE



CERTIFIED

[www.nficertified.org](http://www.nficertified.org)

We suggest that our woodburning hearth products be installed and serviced by professionals who are certified in the U.S. by the National Fireplace Institute® (NFI) as NFI Woodburning Specialists or who are certified in Canada by Wood Energy Technical Training (WETT).



WH Report No. 629-915173A

## TABLE OF CONTENTS

Safety Rules .....	page 2
Tools and Building Supplies .....	page 2
Precautions .....	page 3
Introduction .....	page 3
Clearances/Height Requirements .....	page 3
Chimney System .....	page 3
Assembly Outline .....	page 4
Location of Fireplace .....	page 4
Assembly Steps .....	page 5
Preinstallation Notes .....	page 5
Clearances .....	page 5
Installing the Fireplace .....	page 5
Fireplace Specifications .....	page 6
Framing Specifications .....	page 7
Installing the Chimney System .....	page 8
30° Offset through Floor/Ceiling .....	page 9
Ten Foot Rule Summary .....	page 11
Multiple Terminations .....	page 11
Chimney Component Calculations ...	page 11
Special Offset Instructions .....	page 12
Offset Calculations .....	page 12
Vertical Elevation Chart .....	page 13
Offset Elevation Chart .....	page 14
Installing Offsets .....	page 14
Combustion Air Kits .....	page 15
Optional Equipment Considerations .	page 15
Gas Line Connection .....	page 15
Vent Free Appliances .....	page 16
Glass Doors .....	page 16
Cold Climate Insulation .....	page 16
Fireplace Finishes .....	page 16
Mantels and Trim .....	page 16
Hearth Extensions/Wall Shields .....	page 16
Finish Requirements .....	page 18
Installation Components .....	page 19

## IMPORTANT: PLEASE READ AND UNDERSTAND THESE RULES TO FOLLOW FOR SAFETY.

1. Before starting your fireplace installation, read these installation instructions carefully to be sure you understand them completely and in entirety. Failure to follow them could cause a fireplace malfunction resulting in serious injury and/or property damage.

2. Always check your local building codes. The installation must comply with all local, regional, state and national codes and regulations.

3. These fireplaces must be installed with Security Chimneys FTF10 [10" (254mm) inside diameter] Chimney System only. These systems are intended for use in any application where a traditional masonry type fireplace would apply. The chimney system must always vent to the outside of the building.

4. To ensure a safe fireplace system and to prevent the build-up of soot and creosote, inspect and clean the fireplace and chimney prior to use and periodically during the heating season.

5. Use solid fuel only. DO NOT use artificial wax based logs, chemical chimney cleaners or flame colorants in your fireplace.

6. DO NOT use charcoal or coal under any circumstances.

7. NEVER use gasoline, gasoline-type lantern fuel, kerosene, charcoal lighter fluid, or similar liquids to start or "freshen up" a fire in this fireplace. Keep any flammable liquids at safe distance from the fireplace.

8. NEVER leave children unattended when there is a fire burning in the fireplace.

9. Always keep flue damper open when heat is present in the fireplace.

10. Before servicing, allow the fireplace to cool. Always shut off any electricity or gas to the fireplace while working on it. This will prevent any possible electrical shock or burns.

11. This fireplace is not intended to heat an entire home or be used as a primary heat source. It is designed to ensure homeowner comfort by providing supplemental heat to the room.

12. Always ensure that an adequate supply of replacement combustion air from the outside of the house is accessible to the fire to support normal combustion. Fireplaces consume large volumes of air during the normal combustion process. In the event the home is tightly sealed with modern energy efficient features, the optional combustion air kit may not provide all the air required to support combustion.

The manufacturer is not responsible for any smoking or related problems that may result from the lack of adequate combustion air. It is the responsibility of the builder/contractor to ensure that adequate combustion air has been provided for the fireplace.

13. DO NOT use a fireplace insert or any other products not specified herein by the manufacturer for use with this fireplace. All gas log sets must be operated with the damper clamped open, including unlisted "vent free" log sets. Listed "vent-free" log sets may be operated with the damper closed.

14. "Smoke free" operation is not warranted nor are we responsible for inadequate system draft caused by mechanical systems, general construction conditions, inadequate chimney heights, adverse wind conditions and/or unusual environmental factors or conditions beyond our control.

15. Never, under any circumstances, install a fireplace, chimney component or any accessories, that has visible or suspected physical damage as a result of handling or transportation. These items should be inspected by your distributor or qualified factory representative to ensure safe condition. When in doubt, consult your distributor.

16. For additional safety considerations and complete operating instructions, refer to the Care and Operation Manual provided with the fireplace.

## TOOLS AND BUILDING SUPPLIES NORMALLY REQUIRED

Tools should include:

- Phillips screwdriver
- Hammer
- Saw and/or sabersaw
- Level
- Measuring tape
- Plumb line
- Electric drill and bits
- Pliers
- Square

Building supplies:

- Framing materials
- Wall finishing materials
- Caulking materials (noncombustible)
- Fireplace surround and hearth extension materials (noncombustible)

## PRECAUTIONS

**Note:** These fireplace systems are not difficult to install. However, in the interest of safety, it is recommended that the installer be a qualified or certified "tradesman" familiar with commonly accepted fireplace installation and safety techniques as well as prevailing local codes.

The most important areas of concern dealing with the installation of factory-built fireplaces are clearances to combustible materials, proper assembly of component parts, height of the chimney system, the proper use of accessories supplied by the manufacturer and the techniques employed in using finishing materials applied to the wall surrounding the fireplace, hearth extensions and wall shields. Each of these topics will be covered in thorough detail throughout this manual. Please give each your special attention as you progress with your installation.

## INTRODUCTION

### General Information

The LBR Series fireplace is a traditional wood burning radiant heat system. The LBC Series fireplace is a traditional wood burning heat circulating system. These fireplaces come with standard bar grates, optional outside combustion air kits and optional decorative glass doors.

## TYPICAL INSTALLATION

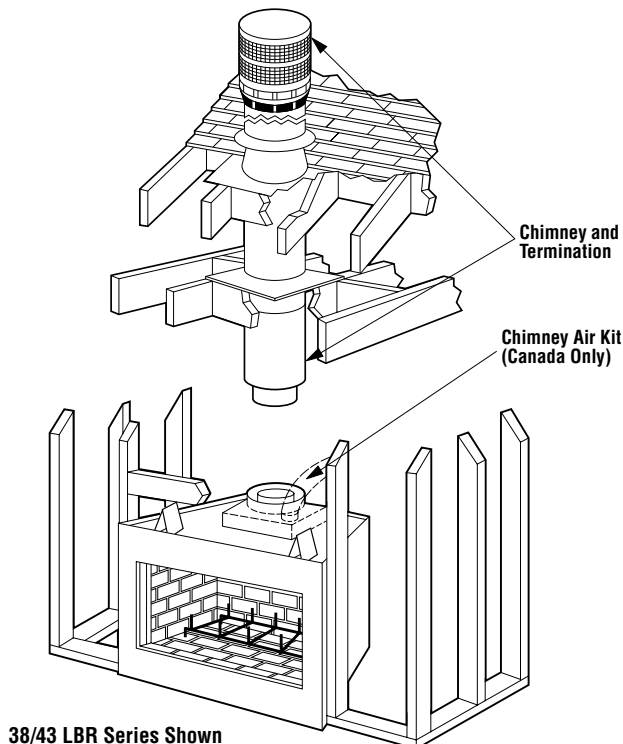

Figure 1

**Note:** Illustrations shown reflect "typical" installations with nominal dimensions and are for design and framing reference only. Actual installations may vary due to individual design preferences. However, always maintain minimum clearances to combustible materials and do not violate any specific installation requirements.

These fireplaces have been tested and listed by Warnock Hersey (Report No. 629-915173A) to U.L. standard 127 for US and ULC S610 for Canada. These units are intended for installation in residential homes and other buildings of conventional construction including commercial, not in mobile homes.

These fireplace systems are designed for installation in accordance with the National Fire Protection Standard for chimneys, fireplaces and solid fuel burning appliances; NFPA 211 and in accordance with codes such as the BOCA Basic/National Codes, the Standard Mechanical Code and the Uniform Building Codes.

**WARNING: FAILURE TO USE MANUFACTURE PROVIDED PARTS, VARIATIONS IN TECHNIQUES AND CONSTRUCTION MATERIALS OR PRACTICES OTHER THAN THOSE DESCRIBED IN THIS MANUAL MAY CREATE A FIRE HAZARD AND VOID THE LIMITED WARRANTY.**

## IMPORTANT: WHEN INSTALLING THESE FIREPLACES IN CANADA, THE CHIMNEY COLLAR ENCLOSURE KIT, MODEL CCEK, MUST BE INSTALLED.

When complete these fireplace systems consists of four basic "sub-systems":

1. The Fireplace
2. The Chimney and Termination
3. Optional Louver Kits and Glass Doors
4. Optional Combustion Air Kit
5. Optional Cold Climate Kit (Mandatory in Canada).

## CLEARANCES AND HEIGHT REQUIREMENTS

The fireplace may be placed on or near normal construction materials\*. The combustion air kit, firestop spacer and roof flashing (not chase flashings) may be placed directly on or against normal construction materials. \* The chimney requires a minimum 2" air space to combustibles and the fireplace outer wrapper requires a minimum 1/2" air space to combustibles. A combustible mantle may be installed 12" above the opening of the fireplace as per NFPA 211, Section 7-2.3.3. In Canada, the minimum is 18" (441mm) above the fireplace opening.

The minimum installed height of the completed fireplace system is 14' 0". The maximum height is 80' 0".

The fireplace and chimney system must be enclosed when installed in or passing through a living area where combustibles or people may come in contact with it. This is important to prevent possible personal injury or fire hazard.

For questions, please call your distributor or the manufacturer. Special restrictions apply to the front and facing of the fireplace and nearby walls (See pages 16 and 17 ).

## CHIMNEY SYSTEM

These fireplaces are designed and code listed for use with Security Chimneys FTF10 chimney System only. Always use Security Chimneys FTF10 chimney components with these fireplaces. Do not modify or alter these components as this may cause a potential serious hazard and void the Warranty.

\*Construction Materials:

- framing materials
- particle board
- millboard
- plywood
- paneling
- flooring
- dry wall
- etc.

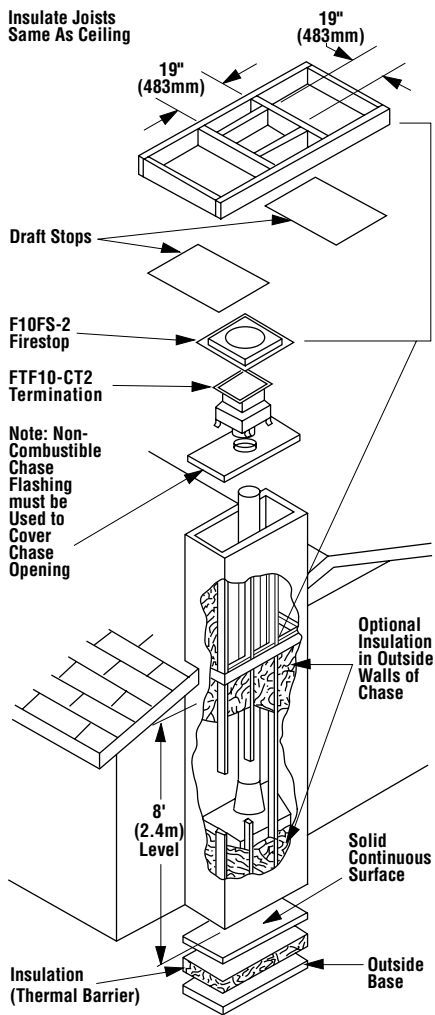

Figure 2

**WARNING: IF INSULATION IS USED, THE FIREPLACE MUST NOT BE PLACED DIRECTLY AGAINST IT. INSULATION OR VAPOR BARRIERS, IF USED, MUST FIRST BE COVERED WITH GYPSUM BOARD, PLYWOOD, PARTICLE BOARD OR OTHER MATERIAL TO ASSURE INSULATION AND VAPOR BARRIERS REMAIN IN PLACE.**

**WARNING: DO NOT PACK OR FILL REQUIRED AIR SPACES WITH INSULATION OR OTHER MATERIAL. NO MATERIAL IS ALLOWED IN THESE AREAS.**

*Note: Do not insulate the chase cavity with blown or fill type insulation materials.*

*Note: Local codes may not require firestopping at the ceiling levels for outside chase installations. However, it is recommended for safety and the reduction of heat loss.*

### Chimney Height

The total height of your completed fireplace system from the surface the fireplace rests on to the chimney top must not exceed 80' (24.4) and must also meet minimum height requirements. Refer to the minimum system height chart.

#### MINIMUM SYSTEM HEIGHT

Security's FTF10 Pipe	
Vertical Installation	14' ( 4.3 m)
One Offset	16' ( 4.9 m)
Two Offsets	24' ( 7.3 m)

### Chase Enclosure

A chase is a vertical box-like structure constructed to surround the fireplace and chimney. Refer to Figure 2 for a typical chase configuration. As with all chimney installations, avoid overhead obstructions such as trees, power lines, etc. A chase should be constructed and insulated just like any outside wall. In a cold climate, we recommend the base of the chase should also be insulated between the solid continuous floor beneath the fireplace and the chase bottom. Chase insulation in a cold climate installation is not required for safety.

### ASSEMBLY OUTLINE

#### Before You Start

Check your inventory list to be sure you have all the necessary parts supplied in good usable condition. Check also for any concealed damage.

Check the operation of the damper. The damper is controlled through the use of a control lever located within the firebox opening at the bottom left side, just behind the firebox screen (Figure 3). The control lever snaps into place at the extreme range of motion, up and back in the closed position. When pulled forward and down, the damper is open.

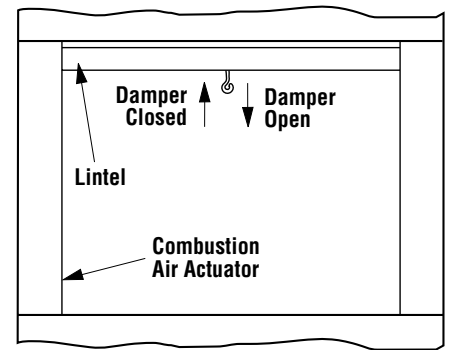

Figure 3

### LOCATION OF FIREPLACE

Carefully select the proper location for heat circulation, aesthetics, chimney obstructions and clearance to side wall(s). With proper pre-planning, a slight adjustment of a few inches can save considerable time and expense later during construction and assembly.

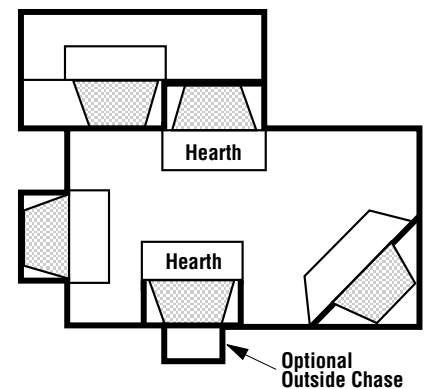
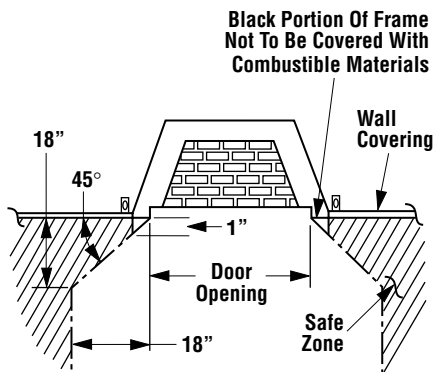

Figure 4

Carefully consider the position of the fireplace opening with respect to the location of adjacent or nearby stairwells, bath or kitchen exhaust fans and/or return air registers for forced air furnaces/air conditioners that could cause a smoking fireplace condition if the house is tightly insulated.

When locating the fireplace, consideration must be given to combustibles and final finishing. See Figure 5 and confine the final location of combustible finish materials to the "Safe Zone".



**Figure 5**

DO NOT permanently place furniture or other items such as decorative pillows within 60" of the fireplace front face.

### ASSEMBLY STEPS

**Note:** The following steps represent the normal sequence of installation. Each installation is unique, however, and might require a different sequence.

1. Position firebox prior to framing or into prepared framing.
2. Install the chimney system.
3. Install optional outside combustion air kit.
4. Plumb gas line if a decorative gas appliance will be used. (Gas connections should only be performed by an experienced, licensed/certified tradesman.)
5. Complete the installation, finish wall material, surround and hearth extension to your individual taste.
6. Assemble and attach optional glass door assembly.

Study the three dimensional illustration (*Figure 1*) to get a general idea of each element of your fireplace system.

### PRE-INSTALLATION NOTES

The fireplace may be installed directly on a combustible floor or raised on a platform of an appropriate height. Do not place fireplace on carpeting, vinyl or other soft floor coverings. It may, however, be placed on flat wood, plywood, particle board or other hard surfaces.

Be sure fireplace rests on a solid continuous floor or platform with appropriate framing for support and so that no cold air can enter the room from under the fireplace.

The fireplace may be positioned and then the framing built around it, or the framing may be constructed and the fireplace positioned into the opening.

Usually, no special floor support is needed for the fireplace, however, to be certain:

1. Estimate the total weight of the fireplace system including chimney and surround materials such as brick, stone, etc., to be installed. Shipping weights for the fireplace may be found on page 18.
2. Measure the square footage of the floor space to be occupied by the system, surrounds and hearth extensions.
3. Note the floor construction, i.e. 2 x 6's, 2 x 8's or 2 x 10's, single or double joists, type and thickness of floor boards.
4. Use this information and consult your local building code to determine if you need additional support.

**CAUTION: DO NOT BLOCK THE HEAT-CIRCULATING AIR INLET AND OUTLET PORTS ON CIRCULATING MODELS. DOING SO MAY RESULT IN A POTENTIAL FIRE HAZARD.**

If you plan to raise the fireplace and hearth extension, build the platform assembly then position fireplace and hearth extension on top. Secure the platform to the floor to prevent possible shifting.

### CLEARANCES

Minimum clearance to combustibles for the fireplace is as follows; sides and back – ½" (13mm), combustible floor – 0" (0mm), adjacent wall 18" (457mm), adjacent shielded wall (*K* factor of .84 or less 40" W x 40" H) 12" (305mm), ceiling – 37 ½" (953mm). Refer to page 17 for more detail.

**Note:** Clearance at the nailing flange for both fireplace models is 0" (0mm).

**Note:** Adjacent wall considerations are for an adjacent wall on only a single side. Walls should not be placed at minimum distance at both sides of the fireplace.

### INSTALLING THE FIREPLACE

**Step 1.** Slide the fireplace into prepared framing or position fireplace in its final position and frame later.

The fireplace may not be recessed into a combustible floor. Maintain the floor to hearth clearance established by the fireplace lower front face.

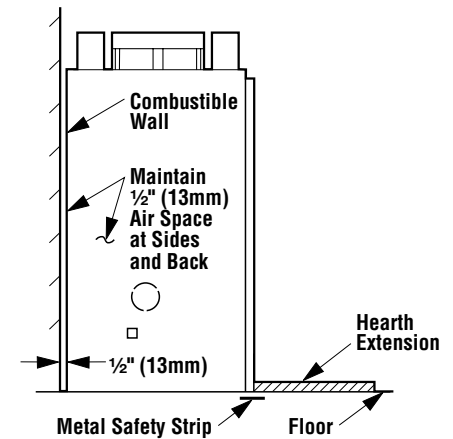

**Figure 6**

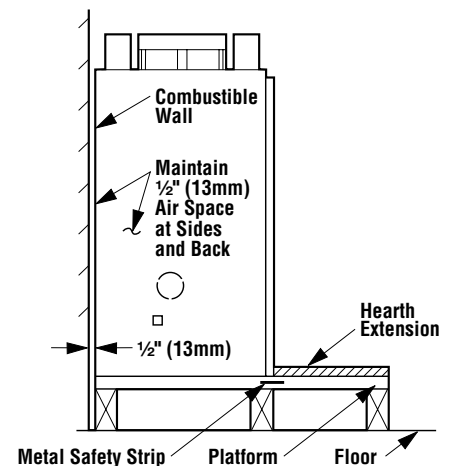

**Figure 7**

**Step 2.** Insert the provided metal safety strips, beneath the fireplace as illustrated (*Figures 6, 7 and 8*). The safety strips should overlap ½" min. for continual coverage of the floor.

**Note:** Safety strips are not required when fireplace rests on a noncombustible surface.

**Note:** Install the hearth extension only as illustrated (see *Figures 43 and 44*).

The safety strips should extend from front of the fireplace at least 1 1/2" and should extend to be at least flush with the sides. In the event a wooden support is used to elevate the fireplace above the floor, a "Z" type safety strip should be fabricated and used to protect the front surface of the wood support as well as the floor beneath the hearth extension (Figures 8 and 9). The safety strips should be tacked down to prevent possible movement.

**Note:** The "Z" type safety strip is not supplied.

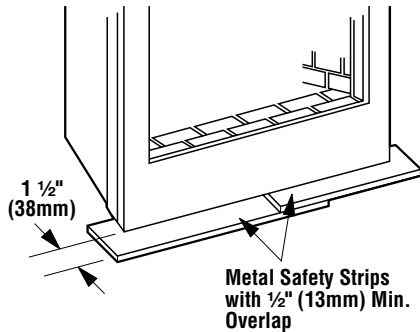

Figure 8

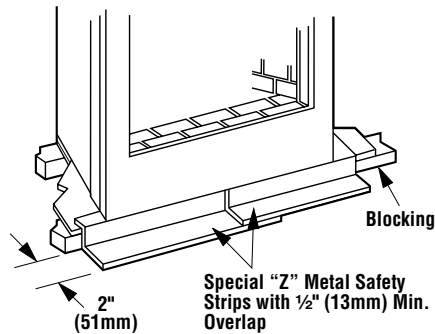
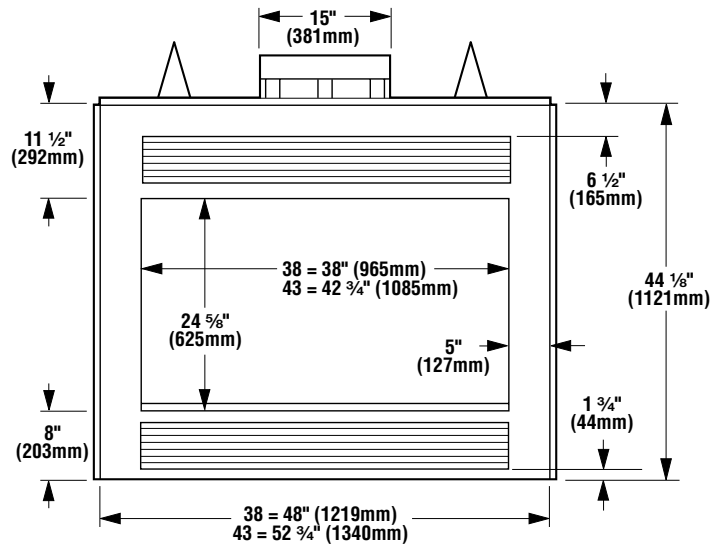

Figure 9

**Step 3.** Refer to fireplace drawings and specifications on pages 6 and 7 for framing dimensions and details. Frame appliance enclosure as illustrated in Figures 11 through 14 on page 7.

**IMPORTANT: UNDER NO CIRCUMSTANCES CAN THE FIREPLACE TOP SPACERS (FIGURE 10) BE REMOVED OR MODIFIED, NOR MAY YOU NOTCH THE HEADER TO FIT AROUND OR BE INSTALLED LOWER THAN THE SPACERS. THE HEADER MAY BE IN DIRECT CONTACT WITH THE TOP SPACERS BUT MAY NOT BE SUPPORTED BY THEM.**

## FIREPLACE SPECIFICATIONS



Front (LBC Shown)

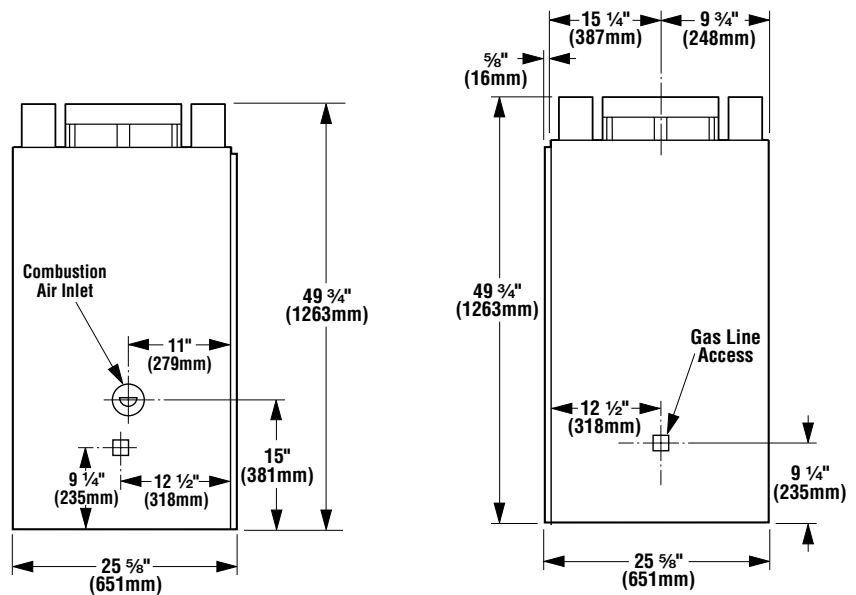

Left Side

Right Side

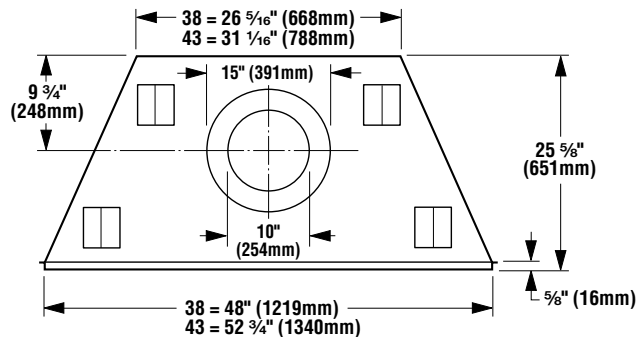

Top View

Figure 10

NOTE: DIAGRAMS & ILLUSTRATIONS NOT TO SCALE.

**Note:** The framed depth, 25 1/2" (648 mm) from a framed wall, must always be measured from a finished surface. If a wall covering such as drywall is to be attached to the rear wall, then the framed depth must be measured from the drywall surface. It is important that this dimension be exact.

If the appliance is to be elevated above floor level, a solid continuous platform must be constructed.

The header may rest on the top metal spacers, but must not be notched to fit around them.

Consult all local codes.

## FRAMING SPECIFICATIONS

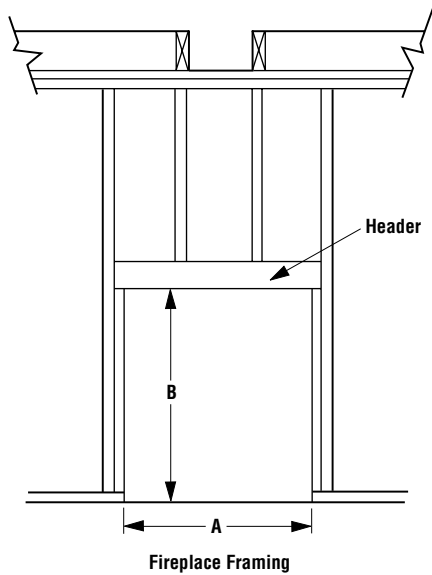

Figure 11

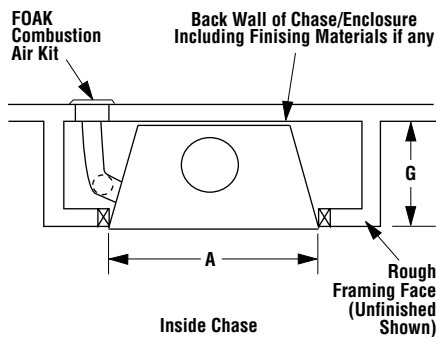

Figure 12

## Framing Dimensions

	Fireplace Opening Width	
	38	43
A	48 1/8" (1222 mm)	52 7/8" (1343 mm)
B	50" (1270 mm)	50" (1270 mm)
C	26 1/4" (667 mm)	31" (787 mm)
D	13 1/8" (334 mm)	15 1/2" (394 mm)
E	77 1/4" (1962 mm)	82" (2083 mm)
F	38 5/8" (981 mm)	41" (1041 mm)
G	25 1/2" (648 mm)	25 1/2" (648 mm)
J	11" (279 mm)	11" (279 mm)
K	54 5/8" (1388 mm)	58" (1473 mm)

**Note:** All framing dimensions calculated for 1/2" dry wall at the fireplace face. If sheathing the chase or finishing with other thickness materials, calculations will need to be made.

## Framing Dimensions for Ceiling

Flue Type	A	B
FTF10 Vertical	19" (483 mm)	19" (483 mm)
FTF10 Offset 30°	19" (483 mm)	29" (737 mm)

## Framing Dimensions for Roof

Pitch	C	D*
0/12	19" (483 mm)	19" (483 mm)
6/12	19" (483 mm)	22" (559 mm)
12/12	19" (483 mm)	27" (686 mm)

\* Perpendicular to roof ridge

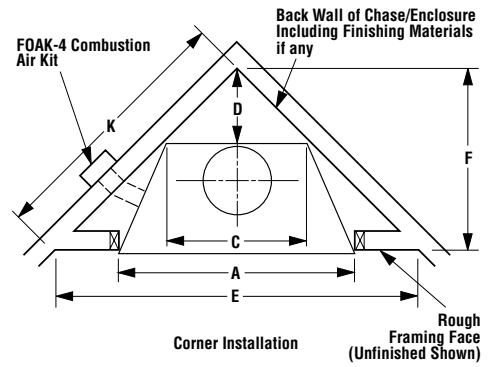

Figure 13

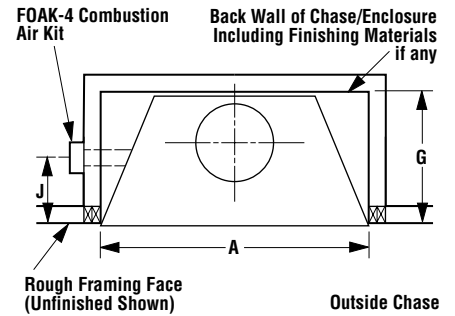

Figure 14

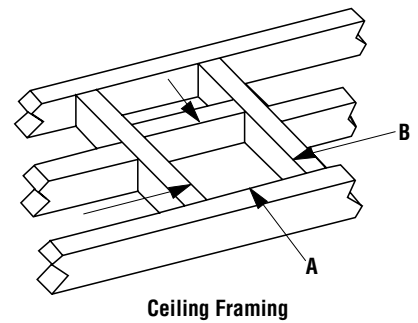

Figure 15

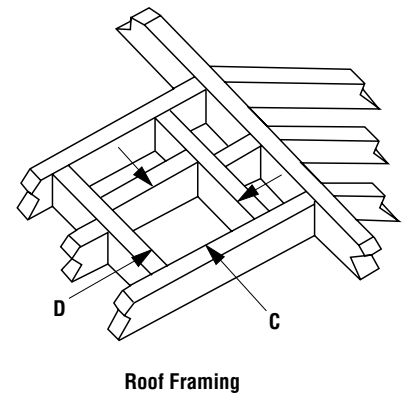
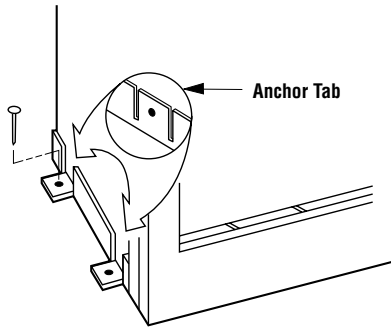

Figure 16

**Step 4.** The fireplace should be anchored to the floor. Bend down the four (4) anchor tabs located at the base of the fireplace and secure to the floor with 8d nails (*Figure 17*).



**Figure 17**

**Step 5.** The fireplace should be secured to the side framing members through the nailing flange (*Figure 18*).

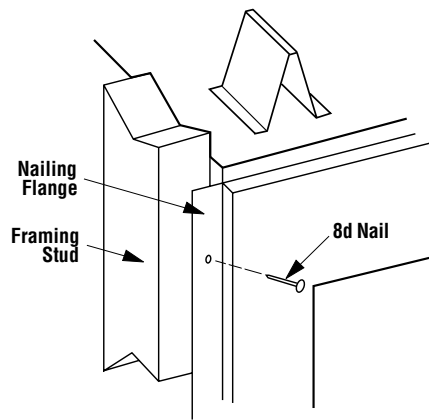

**Figure 18**

**Note:** The nailing flange and the area directly behind the nailing flange is exempt from the clearances described on the fireplace clearance label.

**For Canadian Installations, Proceed with Steps 6 through 9**

**Step 6.** Attach the cold climate kit, Model FTF10-CCK1-LD, around the chimney collar with the screws provided (*Figure 19*).

**Step 7.** Connect the 4" (102 mm) Class 0 air duct provided, to the collar on the chimney collar enclosure with the screws provided in the kit's hardware package.

**Step 8.** Route the Class 0 air duct out the back or side wall, up through the ceiling or floor joists to an outside wall. The duct inlet should be located above snow level or above any anticipated snow level.

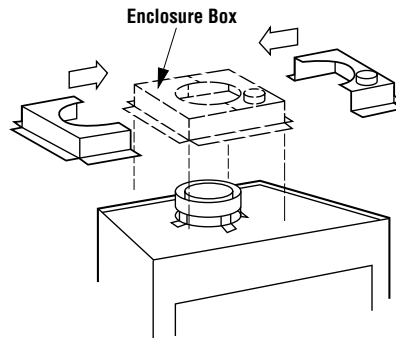

**Figure 19**

**Note:** If the fireplace is installed against an inside wall, the Class 0 air duct may be extended into a ventilated attic space at least 18" (457 mm) above the attic floor. Secure the duct hood to a vertical post with the inlet positioned downward. Ensure that nothing blocks the hood opening. This duct must never terminate higher than the fireplace chimney.

**Step 9.** Cut or frame a hole through the outside wall for the installation of the duct inlet hood. A 4 1/2" (114 mm) diameter hole is required. Feed the loose end of the flexible duct through the hole cut for the inlet hood and attach to the collar on the inlet hood using (2) two screws. Insert the hood into the opening. Secure in place with nails driven through the holes in hood flange. Seal with noncombustible waterproof silicon type caulking. If additional duct is needed, use Class 0 metallic air duct.

**INSTALLING THE CHIMNEY SYSTEM**

**Step 1.** Check the flue damper for proper operation. When the flue damper is in the fully closed position, the damper control lever is pushed all the way to the rear of the firebox. When the damper is in the fully open position, the flue damper control lever is pulled all the way to the front of the firebox.

**Step 2.** Using standard construction framing techniques, construct openings for the chimney through the ceiling(s) and roof or through an outside chase. All framing must maintain the minimum air space clearance at all times.

**CAUTION: ALLOW A MINIMUM 2" (51 MM) CHIMNEY AIR SPACE TO COMBUSTIBLE FRAMING MEMBERS THROUGHOUT VERTICAL AND/OR OFFSET CHIMNEY INSTALLATIONS.**

A minimum 2" (51 mm) air space must be reserved for all combustible and noncombustible materials extending for any continuous length surrounding the chimney.

Reference *Figures 15 and 16* and charts "Framing Dimensions for Ceiling and Roof," which specify minimum ceiling and roof dimensions.

For new construction, to determine chimney center line, use plumb line from ceiling or roof above fireplace to the center of fireplace flue collar.

For remodeling, plumb to the center of the fireplace flue collar from the ceiling or roof above. Drive a nail through the ceiling or roof from below to mark position. Mark and cut a hole in the ceiling (around the nail) (*Figure 20*). Then plumb from ceiling or roof directly above the cut hole to determine roof hole position.

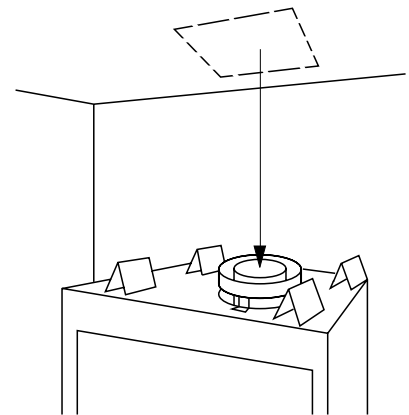

**Figure 20**

**Note:** The optional collar duct kit, Model FTF10-CDK, should be installed after the chimney has been attached to the flue collar.

**Step 3.** Position the appropriate firestop spacer at the ceiling and nail temporarily with two (2) 8d nails. Use a flat firestop spacer, Model F10FS-2, for the FTF10 system if chimney penetrates vertically. If the chimney penetrates through the ceiling at a 30° angle (offset chimney) then use a 30° firestop spacer, Model F10FS30-2. Use one nail on opposite sides of the firestop to hold in position. Nail permanently, using at least two (2) more 8d nails, after the chimney sections have been assembled through the firestop spacer and after necessary adjustments have been made. The firestop spacer must be secured in place by at least four (4) 8d nails when completely installed.

**Note:** If there is a room above the ceiling level, the firestop spacer must be installed on the bottom side of the ceiling. If an attic is above the ceiling level, the firestop spacer must be installed on the top side of the ceiling joists (Figures 21 and 22).

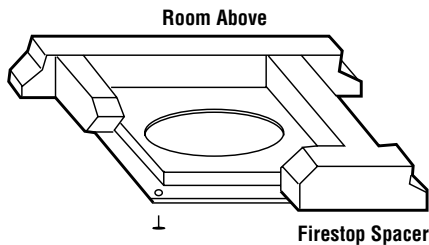

Figure 21

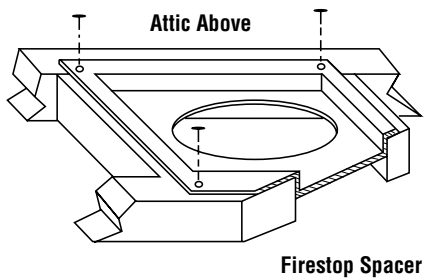

Figure 22

### CHIMNEY 30° OFFSET THROUGH FLOOR OR CEILING

It may be necessary to assemble the chimney at 30° when passing through the floor or ceiling area. Use the F10FS30-2 firestop spacer as shown in Figures 23 and 24. Support the chimney at floor or ceiling penetration with a FTF10 stabilizer if distance of chimney below ceiling is 10' or more. Maintain 2" minimum air space to combustibles from chimney sections.

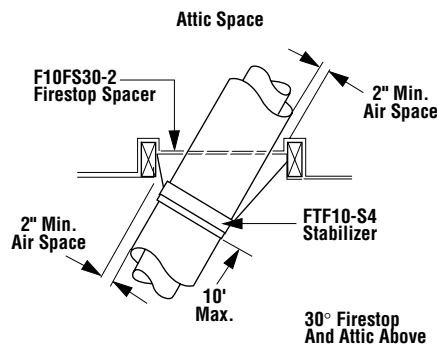

Figure 23

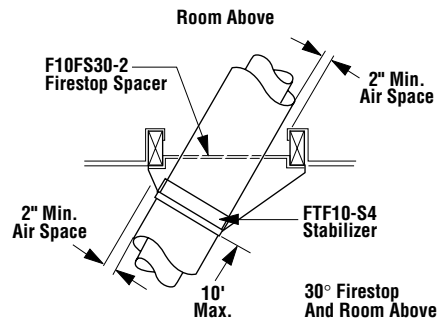

Figure 24

### For Canada Only

When installing the chimney system through an open attic space, the attic shield assembly-firestop spacer must be used (Figure 25). This installation is required only for use in Canada.

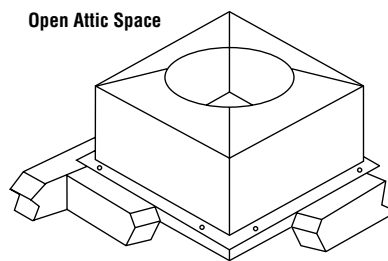

Figure 25

**Step 4. Note:** All chimney sections are constructed with a unique locking tabs and hem design, which ensures an immediate, tight assembly between sections. Plan your chimney requirements carefully before assembly, as the chimney is difficult to disassemble after installation. If disassembled, the tabs might become damaged. Be certain that the tabs are properly formed to ensure they engage properly.

**Note:** For Canadian installations, all chimney installed outside the building must be constructed with galvalume (outer sections only) effective January 1, 1992. The appropriate model designations are located in the back of this manual.

The FTF10 chimney system is a two piece chimney that snap locks together from the fireplace up. Always start with the inner flue section. With the lanced end up, snap lock the joint into the matching collar on top of the fireplace. At all subsequent joints, the upper flue section fits into the lower or preceding flue section. Each section snaps together by means of locking tabs (9 tabs per joint). Check each section by pulling up slightly from the top to ensure proper engagement before installing succeeding sections. If the flue has been installed correctly, it will not separate when tested. Also, the inner flue joint where each section is joined should be tight and flat without gaps (Figure 26).

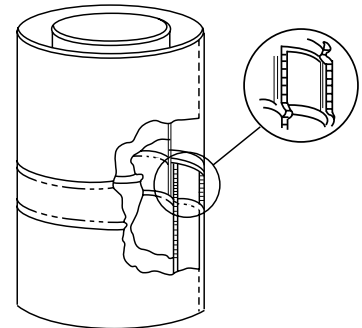

Figure 26

The outer chimney section installs the opposite way; the lanced end goes down and each new section installs OVER the outside of the previous section (Figure 27).

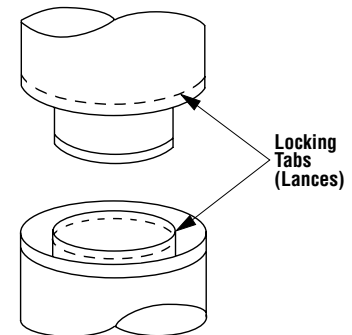
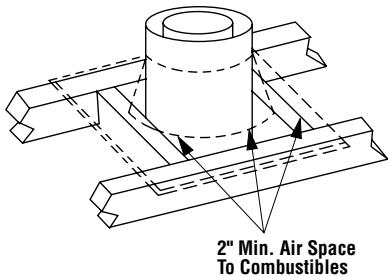

Figure 27

**Note:** Assemble one component of chimney at a time (inner section first; then outer section last) before proceeding with the next complete section.

Continue to assemble the chimney up through framed opening. Assemble just enough to penetrate the roof flashing openings (Figure 28). Always maintain 2" minimum air space to combustible materials and always check each chimney joint (inner and outer) to ensure proper engagement. Check vertical alignment of chimney so that it projects from the roof in true vertical position.



**Figure 28**

Security's chimney sections do not need to be screwed together. Additional reinforcement is not necessary except in certain offset conditions (refer to page 12, Figure 39).

**Step 5.** The height of vertical chimney pipe supported only by the fireplace must not exceed 30'. Chimney heights above 30' must be supported by a Model FTF10-S4 stabilizer installed at 30' intervals.

**Note:** The Model FTF10-S4 adds 3" net effective height to the total chimney system.

Install the Model FTF10-S4 stabilizer by fitting inner section down into respective section of proceeding flue pipe and locking outer stabilizer section into place over the outer chimney pipe. Position for proper clearance through framed opening and nail straps securely (under tension in "shear") into place on framing. Use 8d nails. Attach successive lengths of chimney pipe directly to stabilizer using same techniques as described in Step 4 (Figure 29).

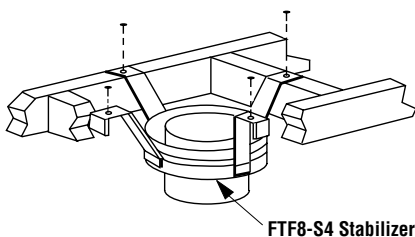

**Figure 29**

**Note:** Do not apply excessive pressure to any subsequent chimney sections following the stabilizer when installing. Ensure each subsequent chimney section is securely attached by testing as noted in Step 4.

**Step 6.** Select the proper Security Chimneys roof flashing based on pitch of roof. Use chart below for selection:

Roof Pitch	Model
Flat to 6/12	F10F6
6/12 to 12/12	F10F12

Next, slide roof flashing over extended chimney section that previously has been installed above the roof opening in Step 4. FTF10 flashings require flashing spacers. Slide flashing all the way down until the flashing base rests flat on the roof (Figure 30). Again, check the vertical position of the chimney and the 2" minimum air space to combustibles.

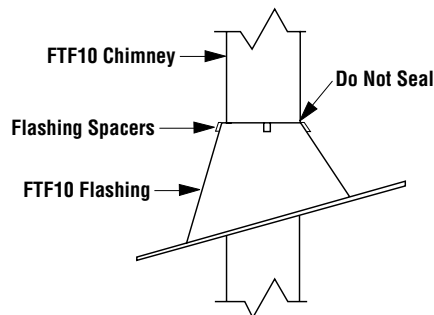

**Figure 30**

**Note:** Do not caulk or seal the ventilating openings.

**Step 7.** Secure flashing by nailing along the perimeter into roof using 8d nails. If shingled roof, slide upper end and sides of roof flashing under shingles (trim if necessary), seal the top and both sides of the flashing to the roof with roof caulking. Cover nail heads with roof caulking (Figure 31).

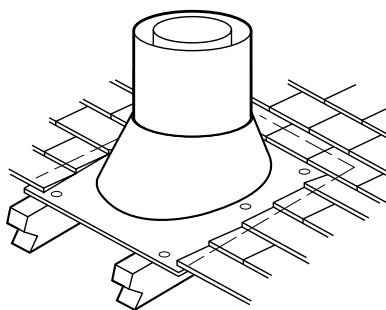

**Figure 31**

**Step 8.** The standard Security FTF10 roof flashing assemblies include a storm collar. Slide the storm collar over outer chimney, rest on flashing spacers and align with top surface of flashing. Insert tab in slot, pull tight and bend tab back over slot. Seal storm collar to outer chimney with roof caulking or mastic around entire circumference of pipe. Also add extra roof caulking to the tab/slot area to seal completely against water penetration (Figure 32). Check all joints very carefully to ensure no water intrusion can take place.

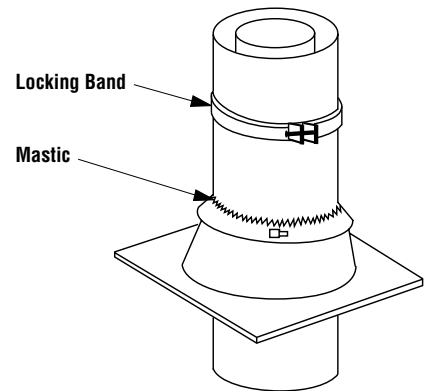

**Figure 32**

**Step 9.** Security Chimneys locking bands, Model FLB, may be required if the chimney extends too high above the roof flashing. As a general rule, if the chimney extends more than 6' above the roof flashing, the use of locking bands is advisable to strengthen the chimney assembly. Align the locking band at the chimney joint. Locking bands wrap around pipe joints equally covering the joints of both pipe sections. Use the nut provided and TIGHTEN snugly. Do not overtighten as this might damage the chimney section (refer to Figure 29).

**Note:** If chimney extends more than 8' above roof surface, guy wires are also recommended. Use three (3) guy wires, attach to locking band assembly, extend and secure to roof in a triangular pattern (Figure 33). Guy wires are not supplied by the manufacturer.

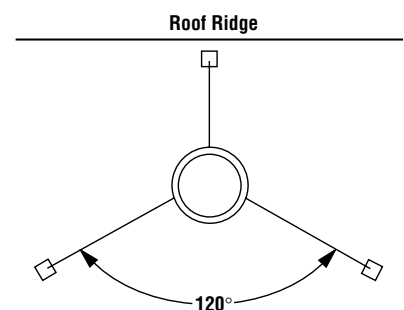

**Figure 33**

**Step 10. Installing a FTF10 CTDTM Round Termination:**

1. Hold the FTF10 CTDTM over the top of the last chimney section installed (Figure 34).
2. Center the inner slip section into inner flue pipe and slip down.

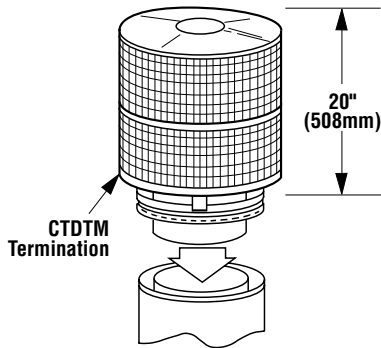

Figure 34

3. Center the outer locking section over outer flue pipe. Push down until all locking tabs are firmly engaged and locked.
4. Pull up slightly on CTDTM to ensure the locking joint is firmly engaged and locked.

**Using a FTF10-CT1 Chase Termination:**

Refer to specific installation instructions included with FTF10-CT1 chase terminations for clearance and installation details.

**Using a FTF10-CT2 Chase Termination:**

Refer to specific installation instructions included with FTF10-CT2 chase terminations for clearance and installation details.

*Note: It is recommended that all exterior exposed metal fireplace components; such as terminations, flashings, storm collars and/or flue be painted with a premium quality, high temperature, rust preventative paint designed for metal. This is especially important when installations are made in abnormally adverse or corrosive environments; such as near lakes, oceans or in areas with consistently high humidity conditions. Consult the paint manufacturers instructions for proper preparation and application.*

**TEN FOOT RULE SUMMARY**

The minimum chimney height above the roof and/or to adjacent walls and buildings is specified by all major building codes.

If the horizontal distance from the peak of the roof is less than 10', the top of the chimney must be at least 2' above the peak of the roof.

If the horizontal distance from the chimney edge to the peak of the roof is more than 10' a chimney height reference point is established on the roof surface 10' horizontally from the chimney edge. The top of the chimney must be at least 2' above this reference point. In all cases, the chimney cannot be less than 3' above the roof at the edge of the chimney.

The 2' in 10' rule is necessary in the interest of safety but does not ensure smoke-free operation. Trees, buildings, adjoining roof lines, adverse wind conditions, etc., may require a taller chimney should the fireplace not draft properly (see Figure 35).

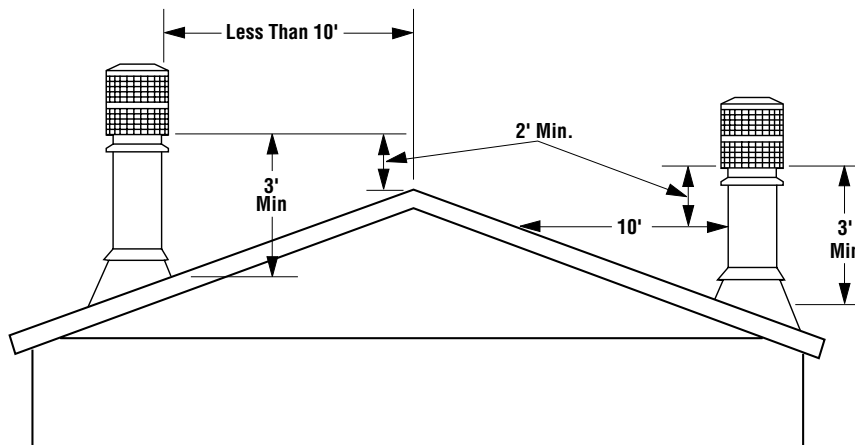

Figure 35

**MULTIPLE TERMINATIONS**

If more than one termination is located in the same chase or within the same general proximity, we suggest they should be separated in distance at least 24" horizontally from flue center to flue center and stacked or staggered vertically at least 18" apart, from the termination of one smoke exit to the termination of another smoke exit (Figure 36).

This suggestion is provided in the interest of better operation. If the terminations are located too close to each other, smoke may migrate from one flue into the other.

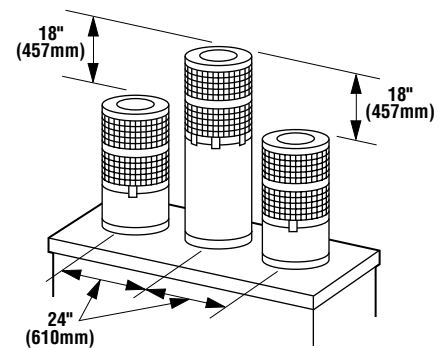

Figure 36

**FTF10 CHIMNEY COMPONENT CALCULATIONS**

The minimum installed height of the completed fireplace system is 15' 0". The maximum height is 60' 0".

To determine the number of chimney sections and chimney components required, follow these steps:

1. Determine total vertical height of the fireplace installation. This dimension is the distance from the surface the fireplace sets on to the point where smoke exits from the termination.
2. Determine the number of chimney components required, except chimney sections. This would include firestop spacers, stabilizers, roof flashing, etc.

**3. The effective heights of the components are:**

The Fireplace	=	48 3/8"
FTF10-12	=	10 1/4"
FTF10-18	=	16 1/4"
FTF10-36	=	34 1/4"
FTF10-CTDTM Termination	=	13"
FTF10-CT1 Termination	=	12" to 18"
FTF10-CT2 Termination	=	15" to 23"
FTF10-S4 Stabilizer *	=	3"*

\* Required for every 30' of vertical chimney and/or 10' of offset chimney.

**4. Determine amount of chimney height required by subtracting total combined height of all pre-selected components (fireplace and chimney components from total desired height.)**

Reference Vertical Elevation Chart and determine the number of chimney sections (quantity and length) required.

**SPECIAL OFFSET INSTRUCTIONS**

To clear any overhead obstructions, you may offset your chimney system using Security's 30° offset and return elbows. Use two elbows - an offset elbow to initiate the offset and a return elbow to terminate it. A 30° offset elbow, angling in any direction, may be the first component used off the top of the fireplace flue collar.

The offset and return elbows may be attached together, or a section or sections of chimney may be used between, but do not exceed 20' in total length between elbows. If sections of pipe exceed 10' between elbows, a chimney stabilizer must be used at the midpoint (Figure 37). The stabilizer support straps must be attached under tension (in shear) to structural framing members above. When two sets of elbows are used, the maximum combined length of chimney used between elbows cannot exceed 20' (Figure 38). **Example:** If C<sub>1</sub> = 10' then C<sub>2</sub> cannot exceed 10'.

If an offset exceeds 6' in length, each chimney joint beyond the first 6' of offset to the return elbow, must be secured by a No. 8 x 1/2" sheet metal screw located at the underside of the joint (Figure 39).

A 1/8" diameter hole must be drilled in the chimney joint using a 1/8" diameter drill. Hole should be drilled in center of joint overlap (see Figure 40). Be sure to drill only through the outer chimney casting. Do not puncture the inner flue.

Maximum offset of chimney system is 30°. Two offsets must not be assembled to form a 60° offset. However, two sets of offset and return elbows may be used on a single flue system, provided the total height of the system exceeds 25'.

Return elbow support straps must be securely attached under tension (in shear) to structural framing members above. Do not substitute a FTF10-30 offset elbow in place of a FTF10-E30 return elbow.

**OFFSET CALCULATIONS**

**Step 1.** Use Offset Chart to determine amount of horizontal offset (A) and height (B) for various chimney section assemblies.

**Step 2.** Use "Height of Chimney Only" column in The Vertical Elevation Chart to determine combinations of chimney used above return elbow to achieve desired heights. Reference Components Effective Height Chart in vertical elevation chart section on page 13.

**Step 3.** Use Elevation Chart as job estimator only. Add necessary firestop spacers and stabilizers as required. Firestop spacers must be used as shown in Figures 23 and 24 and stabilizers as shown in Figure 29.

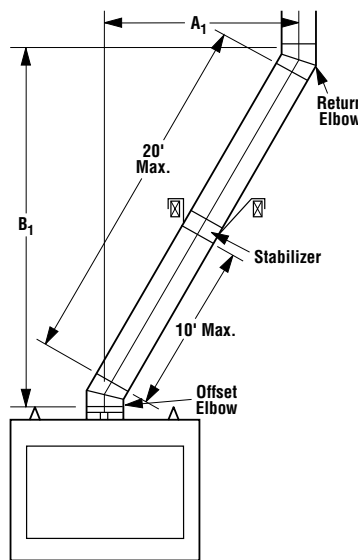

Figure 37

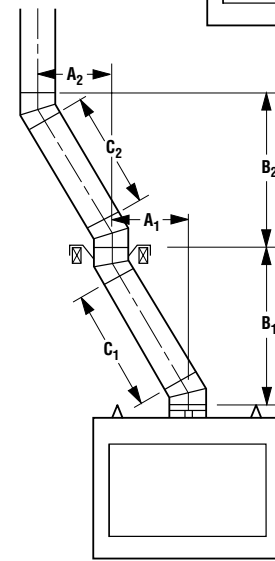
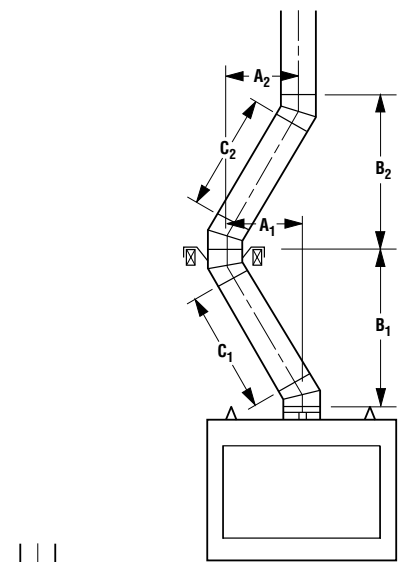

Figure 38

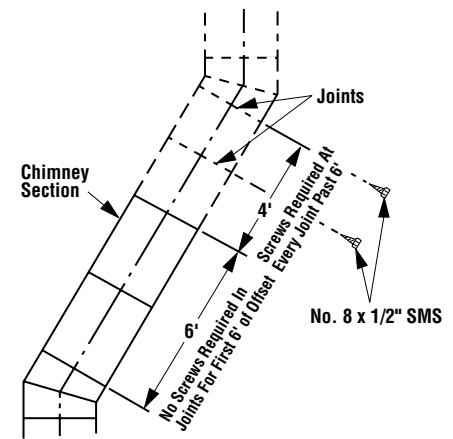

Figure 39

## FTF10 VERTICAL ELEVATION CHART

Height Of Chimney Only		Number Of FTF10 Chimney Lengths			Height Of Chimney Only		Height Of Chimney Only		Number Of FTF10 Chimney Lengths			Height Of Chimney Only	
Inches	Feet/Inches	12"	18"	36"	MM	M	Inches	Feet/Inches	12"	18"	36"	MM	M
11	0 11	1	0	0	279	0.28	461 1/2	38 5 1/2	0	1	13	11722	11.72
17	1 5	0	1	0	432	0.43	465 1/2	38 9 1/2	2	0	13	11824	11.82
21 1/4	1 9 1/4	2	0	0	540	0.54	471 1/2	39 3 1/2	1	1	13	11976	11.98
27 1/4	2 3 1/4	1	1	0	692	0.69	479 1/2	39 11 1/2	0	0	14	12179	12.18
33 1/4	2 9 1/4	0	2	0	845	0.85	489 1/2	40 9 1/2	1	0	14	12433	12.43
35	2 11	0	0	1	889	0.89	495 1/2	41 3 1/2	0	1	14	12586	12.59
37 1/4	3 1 1/4	2	1	0	946	0.95	499 3/4	41 7 3/4	2	0	14	12694	12.69
43 1/4	3 7 1/4	1	2	0	1099	1.10	505 3/4	42 1 3/4	1	1	14	12846	12.85
51 1/4	4 3 1/4	0	1	1	1302	1.30	513 1/2	42 9 1/2	0	0	15	13043	13.04
55 1/4	4 7 1/4	2	0	1	1403	1.40	523 3/4	43 7 3/4	1	0	15	13303	13.30
61 1/4	5 1 1/4	1	1	1	1556	1.56	529 3/4	44 1 3/4	0	1	15	13456	13.46
67 1/4	5 7 1/4	0	2	1	1708	1.71	534	44 6	2	0	15	13564	13.56
69 1/4	5 9 1/4	0	0	2	1759	1.76	540	45 0	1	1	15	13716	13.71
79 1/4	6 7 1/4	1	0	2	2013	2.01	547 3/4	45 7 3/4	0	0	16	13913	13.91
85 1/4	7 1 1/4	0	1	2	2165	2.17	558	46 6	1	0	16	14173	14.17
89 1/2	7 5 1/2	2	0	2	2273	2.27	564	47 0	0	1	16	14326	14.33
95 1/2	7 11 1/2	1	1	2	2426	2.43	568 1/4	47 4 1/4	2	0	16	14434	14.43
103 1/4	8 7 1/4	0	0	3	2622	2.62	574 1/4	47 10 1/4	1	1	16	14586	14.59
113 1/2	9 5 1/2	1	0	3	2883	2.88	582	48 6	0	0	17	14783	14.78
119 1/2	9 11 1/2	0	1	3	3035	3.03	592 1/4	49 4 1/4	1	0	17	15043	15.04
123 3/4	10 3 3/4	2	0	3	3143	3.14	598 1/4	49 10 1/4	0	1	17	15196	15.20
129 3/4	10 9 3/4	1	1	3	3296	3.30	602 1/4	50 2 1/4	2	0	17	15297	15.30
137 1/2	11 5 1/2	0	0	4	3493	3.49	608 1/4	50 8 1/4	1	1	17	15450	15.45
147 3/4	12 3 3/4	1	0	4	3753	3.75	616 1/4	51 4 1/4	0	0	18	15653	15.65
153 3/4	12 9 3/4	0	1	4	3905	4.91	626 1/4	52 2 1/4	1	0	18	15907	15.91
158	13 2	2	0	4	4013	4.01	632 1/4	52 8 1/4	0	1	18	16059	16.06
164	13 8	1	1	4	4166	4.17	636 1/2	53 0 1/2	2	0	18	16167	16.17
171 3/4	14 3 3/4	0	0	5	4362	4.36	642 1/2	53 6 1/2	1	1	18	16320	16.32
182	15 2	1	0	5	4623	4.62	650 1/4	54 2 1/2	0	0	19	16516	16.52
188	15 8	0	1	5	4775	4.78	660 1/2	55 0 1/2	1	0	19	16777	16.78
192	16 0	2	0	5	4877	4.88	666 1/2	55 6 1/2	0	1	19	16929	16.93
198	16 6	1	1	5	5029	5.03	670 3/4	55 10 3/4	2	0	19	17037	17.04
206	17 2	0	0	6	5232	5.23	676 3/4	56 4 3/4	1	1	19	17189	17.19
215 3/4	17 11 3/4	1	0	6	5480	5.48	684 1/2	57 0 1/2	0	0	20	17386	17.39
222	18 6	0	1	6	5639	5.64	694 3/4	57 10 3/4	1	0	20	17647	17.65
226 1/4	18 10 1/4	2	0	6	5747	5.75	700 3/4	58 4 3/4	0	1	20	17799	17.80
232 1/4	19 4 1/4	1	1	6	5899	5.90	705	58 9	2	0	20	17907	17.91
240	20 0	0	0	7	6096	6.10	711	59 3	1	1	20	18059	18.06
250 1/4	20 10 1/4	1	0	7	6356	6.36	718 3/4	59 10 3/4	0	0	21	18256	18.26
256 1/4	21 4 1/4	0	1	7	6509	6.51	729	60 9	1	0	21	18517	18.52
260 1/2	21 8 1/2	2	0	7	6617	6.62	735	61 3	0	1	21	18669	18.67
266 1/2	22 2 1/2	1	1	7	6769	6.77	739	61 7	2	0	21	18771	18.77
274 1/4	22 10 1/4	0	0	8	6966	6.97	745	62 1	1	1	21	18923	18.92
284 1/2	23 8 1/2	1	0	8	7226	7.23	753	62 9	0	0	22	19126	19.13
290 1/2	24 2 1/2	0	1	8	7379	7.38	763	63 7	1	0	22	19380	19.38
294 3/4	24 6 3/4	2	0	8	7487	7.49	769	64 1	0	1	22	19533	19.53
300 3/4	25 0 3/4	1	1	8	7639	7.64	773 1/4	64 5 1/4	2	0	22	19641	19.64
308 1/2	25 8 1/2	0	0	9	7836	7.84	779 1/4	64 11 1/4	1	1	22	19793	19.79
318 3/4	26 8 3/4	1	0	9	8096	8.10	787	65 7	0	0	23	19990	19.99
324 3/4	27 0 3/4	0	1	9	8249	8.25	797 1/4	66 5 1/4	1	0	23	20250	20.25
328 3/4	27 4 3/4	2	0	9	8350	8.35	803 1/4	66 11 1/4	0	1	23	20403	20.40
334 3/4	27 10 3/4	1	1	9	8503	8.50	807 1/2	67 3 1/2	2	0	23	20511	20.51
342 3/4	28 6 3/4	0	0	10	8706	8.71	813 1/2	67 9 1/2	1	1	23	20663	20.66
352 3/4	29 4 3/4	1	0	10	8960	8.96	821 1/4	68 5 1/4	0	0	24	20860	20.86
358 3/4	29 10 3/4	0	1	10	9112	9.11	831 1/2	69 3 1/2	1	0	24	21120	21.12
363	30 3	2	0	10	9220	9.22	837 1/2	69 9 1/2	0	1	24	21273	21.27
369	30 9	1	1	10	9373	9.37	841 3/4	70 1 3/4	2	0	24	21380	21.38
376 3/4	31 4 3/4	0	0	11	9569	9.57	847 3/4	70 7 3/4	1	1	24	21533	21.53
387	32 3	1	0	11	9829	9.83	855 1/2	71 3 1/2	0	0	25	21730	21.73
393	32 9	0	1	11	9982	9.98	865 3/4	72 1 3/4	1	0	25	21990	21.99
397 1/4	33 1 1/4	2	0	11	10090	10.09	871 3/4	72 6 3/4	0	1	25	22142	22.14
403 1/4	33 7 1/4	1	1	11	10243	10.24	875 3/4	72 11 3/4	2	0	25	22244	22.24
411	34 3	0	0	12	10439	10.44	881 3/4	73 5 3/4	1	1	25	22396	22.40
421 1/4	35 1 1/4	1	0	12	10700	10.70	889 3/4	74 1 3/4	0	0	26	22600	22.60
427 1/4	35 7 1/4	0	1	12	10852	10.85	899 3/4	74 11 3/4	1	0	26	22854	22.85
431 1/2	35 11 1/2	2	0	12	10960	10.96	905 3/4	75 5 3/4	0	1	26	23006	23.01
437 1/2	36 5 1/2	1	1	12	11113	11.11	910	75 10	2	0	26	23114	23.11
445 1/4	37 1 1/4	0	0	13	11309	11.31	916	76 4	1	1	26	23266	23.27
455 1/2	37 11 1/2	1	0	13	11570	11.57	924	77 0	0	0	27	23470	23.47

## FTF10 OFFSET ELEVATION CHART

A Offset (Inches)	B Height (Inches)	FTF10-ES30 Offset/Return Elbow Set	FTF10-S4 Stabilizer	Number of FTF10 Chimney Sections			A Offset (mm)	B Height (mm)
				12"	18"	36"		
4	15 3/4	1	0	0	0	0	102	400
9	24 1/2	1	0	1	0	0	229	622
12	29 3/4	1	0	0	1	0	305	756
14 1/4	33 1/2	1	0	2	0	0	362	851
17 1/4	38 1/2	1	0	1	1	0	438	978
20 1/4	43 3/4	1	0	0	2	0	514	1111
21	45 1/4	1	0	0	0	1	533	1149
22 1/4	47 1/2	1	0	2	1	0	565	1207
25 1/4	52 1/2	1	0	1	2	0	641	1334
26 1/4	54 1/4	1	0	1	0	1	667	1378
28 1/4	57 3/4	1	0	0	3	0	718	1467
29 1/4	59 1/4	1	0	0	1	1	743	1505
31 1/4	63	1	0	2	0	1	794	1600
32 1/2	65	1	0	4	1	0	826	1651
34 1/4	68 1/4	1	0	1	1	1	870	1734
36 1/4	71 3/4	1	0	3	0	1	921	1822
37 1/4	73 1/4	1	0	0	2	1	946	1861
38 1/4	75	1	0	0	0	2	972	1905
39 1/4	77	1	0	2	1	1	997	1956
41 1/2	80 1/2	1	0	1	4	0	1054	2045
43 1/4	83 3/4	1	0	1	0	2	1099	2127
44 1/2	85 3/4	1	0	3	1	1	1130	2178
45 1/4	87 1/2	1	0	0	3	1	1149	2223
46 1/4	89	1	0	0	1	2	1175	2261
48 1/4	91 1/2	1	0	2	0	2	1226	2324
49 1/2	94 1/2	1	0	1	5	0	1257	2400
51 1/4	97 3/4	1	0	1	1	2	1302	2483
54 1/4	103	1	0	0	2	2	1378	2616
55 1/4	104 1/2	1	0	0	0	3	1403	2654
56 1/2	106 1/2	1	0	2	1	2	1435	2705
59 1/2	111 3/4	1	0	1	2	2	1511	2838
62 1/2	116 3/4	1	1	1	0	3	1588	2965
65 3/4	122	1	1	0	1	3	1664	3099
67 3/4	125 1/2	1	1	2	0	3	1721	3188
69 3/4	128 1/2	1	1	1	3	2	1772	3264
70 3/4	130 3/4	1	1	1	1	3	1797	3321
73 3/4	136	1	1	0	2	3	1873	3454
75 3/4	139 1/2	1	1	2	1	3	1924	3543
79 3/4	146 1/4	1	1	1	0	4	2026	3715
81	148 1/4	1	1	3	1	3	2057	3766
82 3/4	151 1/2	1	1	0	1	4	2102	3848
87 3/4	160 1/4	1	1	1	1	4	2229	4070

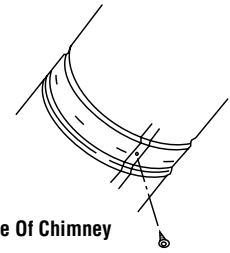

Underside Of Chimney

**Figure 40**

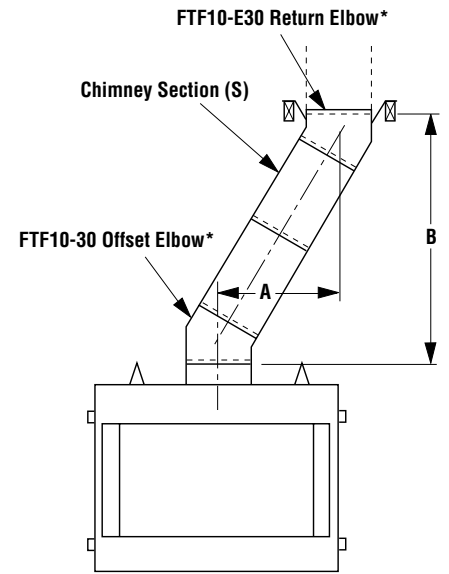

\*Part of Offset/Return Package Model FTF10-ES30

**Figure 41**

### INSTALLING OFFSETS

First, review the Offset Elevation Chart and *Figure 41* for reference.

**Step 1.** Determine the offset distance where chimney is to pass through the first ceiling-dimension "A." To find this point on your ceiling, first determine the center point for a vertical chimney following the instructions for vertical installation.

Measure height to the ceiling from the top of fireplace-dimension "B." Use the appropriate Offset Elevation Chart to find dimension "A." Mark point where you will drive your nail to show the center point for your offset ceiling cut.

**Step 2.** Proceed by using the Straight Up Installation Instructions for cutting and framing ceiling and roof openings.

**Note:** See *Framing and Dimension Chart* for the sizes of the ceiling and roof openings. The size of the roof opening varies with the degree of pitch of the roof.

## Offset Elbow Assembly

Offset elbows install the same as chimney sections. First, snap the inner section INTO the preceding inner section of flue. Check connection by pulling up slightly to ensure a tight fit. Next, the outer sections snap lock OVER the preceding outer section of chimney. Again, check outer section by pulling up slightly to ensure proper connection is made.

## Return Elbow Assembly

Return elbows install the same way as round terminations and stabilizers:

**Step 1.** Hold return elbow over top of last chimney section.

**Step 2.** Center inner slip section into inner flue pipe-slip down.

**Step 3.** Center outer-locking section over outer chimney pipe. Push down until locking joint has firmly engaged.

**Step 4.** Pull up slightly on return elbow to ensure locking joint has firmly engaged.

**Step 5.** Secure support straps to framing members by nailing under tension in sheer (Figure 42).

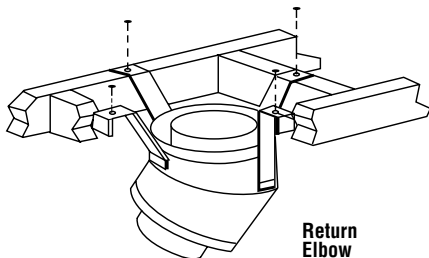

Figure 42

**Note:** The return elbow assembly performs the same function as a stabilizer. Consider this when determining the need for a stabilizer.

**Note:** Do not apply excessive pressure to any subsequent chimney section following return elbow assembly when installing. Ensure that each subsequent chimney section is securely attached by testing as noted above.

## Combustion Air Kits

You may use the combustion air kit, Model FOAK-4 or FOAK-4LD, with the LBR/LBC Series fireplaces. Refer to the installation instructions packed with the air kit for specific installation information. The outside air kit must be installed before the fireplace is totally framed and enclosed within the finished walls.

The combustion air kit provides for outside air to be drawn into the fireplace as an aid for combustion. If installed, only one combustion air kit is needed and it will be installed on the left side of the fireplace. If additional length of air duct is necessary, purchase locally available U.L. Class 0 or Class 1 metallic duct. The duct may extend up to 50' (15.24 m) in any direction.

**Note:** When installing the air duct vertically, DO NOT terminate the air duct closer than 3' (914 mm) below the chimney top.

There is a hand operated shut-off lever located in the left side of the fireplace opening behind the screen. To open, pull all the way. The combustion air damper should be fully open when the fireplace is in use and completely closed when the fireplace is not being used. This will prevent outside cold air from entering the dwelling.

Operate the actuator through several cycles including the "lock position. Ensuring proper operation and freedom of movement. Return the actuator arm to the locked position.

**CAUTION: NEVER LOCATE THE AIR INLET WHERE IT COULD BE BLOCKED BY SHRUBS, SNOWDRIFTS, ETC. NEVER LOCATE AIR INLET IN A GARAGE OR IN ANY AREA WHERE THERE IS ANOTHER FUEL BURNING APPLIANCE OR PRODUCTS EMITTING COMBUSTIBLE GASES SUCH AS PAINT, GASOLINE, ETC. IN COLD CLIMATES IT IS RECOMMENDED THAT THE COMBUSTION AIR DUCT BE INSULATED.**

The outside air ducting may be installed upwards through framing and ceiling joists, with the inlet hood installed through an outside wall. Air ducting may also be installed downward through floor joists and under the dwelling to a ventilated crawlspace not considered part of the living area.

**Note:** Do Not terminate the combustion air kit in an attic space under any circumstances.

## Forced Air Kit

If you are installing the Lennox Forced Air Kit, Model LFAK-2000, see the instruction sheet provided with the kit for electrical wiring requirements. The fireplace has been pre-wired at the factory but must be connected to main power supply at the time of installation if the LFAK-2000 is to be installed later. The electrical connections must be made before the fireplace is framed and enclosed in the finished walls.

**CAUTION: ELECTRICAL CONNECTIONS SHOULD ONLY BE PERFORMED BY A QUALIFIED, LICENSED ELECTRICIAN. MAIN POWER MUST BE OFF WHEN CONNECTING FANS TO MAIN ELECTRICAL POWER SUPPLY OR PERFORMING SERVICE.**

## Variable Speed Wall Switch

Refer to the installation instructions provided with the Variable Speed Wall Switch, Model VSWS, for installation details.

## OPTIONAL EQUIPMENT CONSIDERATIONS

### Gas Line Connection

Always plumb gas line installation per local codes. Check all connections with soap suds; leaks will bubble. Never test any gas line connection with a match or open flame.

This provision is intended for connection to a decorative gas appliance incorporating an automatic shut-off device and complying with the Standard for Decorative Gas Appliances for installation in vented fireplaces, ANSI Z21.60 (1991) or American Gas Association draft requirements for Gas-Fired Log Lighters for Wood Burning Fireplaces, Draft No. 4 dated August, 1993. Install in accordance with the National Fuel Gas Code, ANSI Z223.1. This complies with the revised U.L. 127 standard.

## Vent Free Appliances

These units have been tested and approved to ANSI/IAS/AGA Z21.11.2 for use with unvented gas appliances and complies with the standard for Factory-Built fireplaces, UL 127.

The unit has been tested for use with any unvented gas log sets having a maximum rating of 40,000 BTU. The minimum mantle configurations are outlined in *Figures 43 and 44*.

These fireplaces have been marked with a maximum rating of 40,000 BTU to assure that homeowners do not exceed the allowable limits for all allowed installations of mantles.

**NEVER INSTALL AN UNVENTED GAS LOG SET WITH A BTU GREATER THAN 40,000.**

**CAUTION: WHEN USING THE DECORATIVE GAS APPLIANCE, THE FIREPLACE DAMPER MUST BE SET IN THE FULLY OPEN POSITION.**

**CAUTION: PLUMBING CONNECTIONS SHOULD ONLY BE PERFORMED BY A QUALIFIED, LICENSED PLUMBER. MAIN GAS SUPPLY MUST BE OFF WHEN PLUMBING GAS LINE TO FIREPLACE OR PERFORMING SERVICE.**

If you're installing a gas line, connect it before the fireplace is framed and enclosed in the finished wall. The gas knockout is determined by the indentation located at the bottom and slightly off center in the side refractories. **THE KNOCKOUT IS ALWAYS REMOVED FROM INSIDE THE FIREPLACE. DO NOT REMOVE THE KNOCKOUT UNLESS YOU ARE INSTALLING A GAS LINE.** If removal is attempted from the outer wrapper, side refractory damage may occur. With a medium-sized hammer, lightly tap the surface of the indentation. The refractory material is very thin in this area and is easily removed. Once a small hole has been made, continue tapping until you have reached sufficient diameter for the gas line to fit through. The entire knockout does not have to be removed. Remove insulation in the gas line channel.

**IMPORTANT: REPACK INSULATION MATERIAL IN SQUARE HOLE AROUND GAS LINE, INTERIOR AND EXTERIOR OF FIREPLACE, TO SEAL.**

## Glass Doors

If glass doors are to be installed on these fireplaces, refer to specific installation instructions packed with the glass doors. Use only the doors that are listed for use with these fireplaces. Use of other non-listed glass door on these fireplaces may constitute a potential fire hazard and is not recommended.

**CAUTION: CERTAIN GLASS DOORS OVERLAP THE BLACK METAL FACING OF THE FIREPLACE. IF THE FIREPLACE HAS BEEN FACED WITH NONCOMBUSTIBLE MATERIALS, THERE MIGHT NOT BE SUFFICIENT CLEARANCE TO INSTALL THE GLASS DOORS OF YOUR CHOICE. ENSURE ADEQUATE CLEARANCE IS MAINTAINED AT ALL TIMES SO AS NOT TO INTERFERE WITH THE INSTALLATION AND OPERATION OF GLASS DOORS.**

## COLD CLIMATE INSULATION

If you live in a cold climate, it is especially important to seal all cracks around the fireplace opening with noncombustible material and wherever cold air could enter the room. Surrounding materials must be caulked where it meets the black metal facing of the fireplace to avoid cold air intrusion. Use noncombustible caulking material only on fireplace facing to seal. Also, the outside air inlet duct should be wrapped with noncombustible insulation to minimize the formation of condensation. Do not place insulation materials on top of fireplace or against chimney sections.

*Note: A 2" air space must be preserved for all combustible materials extending for any continuous length adjacent to the chimney.*

It is especially important to insulate between the studs of an outside chase cavity and under the floor if the floor is above ground level. Do not place insulation directly against the fireplace or chimney system.

The installation of the CCK1 is recommended. Refer to Steps 6 thru 9 on Page 8.

## FIREPLACE FINISHES

It is sometimes best to frame your fireplace after it is positioned and the chimney is installed. Frame enclosure for chimney and fireplace with 2 x 4's (or heavier) lumber.

*Note: The header may rest on the two (2) metal top spacers on top of the unit but the header must not be notched to fit around the spacers.*

## Mantels and Trim

These fireplaces may sit directly on a combustible surface. A 2" air space is required between combustible framing and the chimney. In Canada, the minimum height for a combustible mantle is 18" (457 mm) above the fireplace opening. *Figure 43* shows typical Canadian installations. For installations other than Canada, combustible mantels and trim may either project in front or be flush with the finished wall as per NFPA 211 section 7-2.3.3. and *Figure 44*.

If a mantel is of a noncombustible material, it is exempt from these requirements as long as it does not interfere with the installation or operation of glass doors, or block the air circulating opening of the fireplace

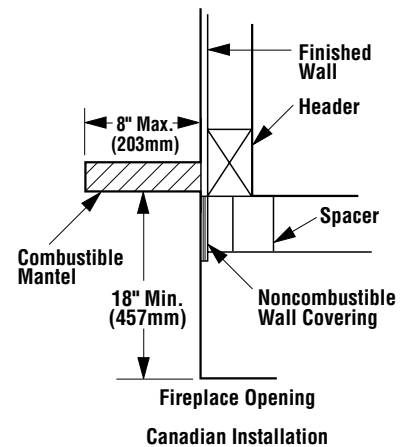

*Figure 43*

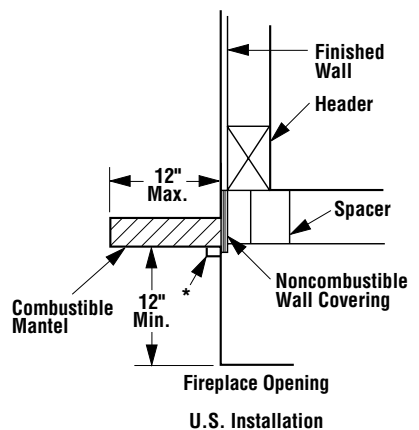

\* A 1½" Projection Is Permitted Between The Face Top And Mantle

*Figure 44*

## Hearth Extensions and Wall Shields

A hearth extension must be installed with all fireplaces. It is to protect the combustible floor in front of the fireplace from both radiant heat and sparks. The hearth extension must extend 8" beyond both sides of the fireplace opening and 16" beyond the front (see *Figure 45*). Use a hearth extension constructed of a durable noncombustible material having an equal or better (lower k value) insulating value of  $k = .84 \text{ BTU IN/FT}^2 \text{ HR } ^\circ\text{F}$  or a thermal resistance that equals or exceeds  $r = 1.19 \text{ HR } ^\circ\text{F FT}^2/\text{BTU IN}$ . With these values, determine the minimum thickness/material required using the formula and *Page 17*.

**Hearth Extension Dimensions**

Opening Width	38"	43"
A	20" (508 mm)	20" (508 mm)
B	38" (965 mm)	43" (1092 mm)
C	12" (305 mm)	12" (305 mm)
D	62" (1575 mm)	67" (1702 mm)

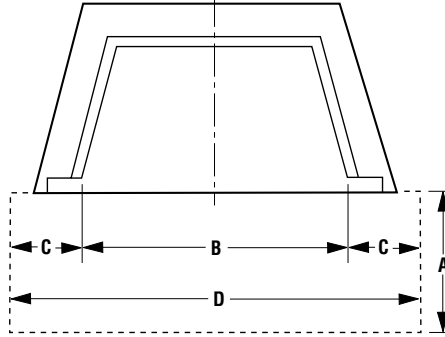

**Figure 45**

**Methods of Determining Hearth Extension and Wall Shield**

**Equivalents** - To determine the thickness required for the alternate material when either the “k” value or “r” value is known, use either the **k formula** or **r formula**.

**Example:** If Micore 160 is to be used for the hearth extension fireplace, how thick must this material be?

- $k_M$  = k value per inch of **alternate** material
- $r_M$  = r value per inch of **alternate** material
- $T_M$  = minimum thickness required for **alternate** material
- $T_S$  = standard thickness of the **alternate** material

- $k_L$  = k value per inch of **listed** material
- $r_L$  = r value per inch of **listed** material
- $T_L$  = minimum thickness of **listed** material

**Note:** An asterix “\*” indicates, it is a value taken from **Table 1**.  
**Using the k formula:**

Minimum thickness of alternate material ( $T_M$ ) =  $\frac{\text{k-value (per Inch) of alternate material } (k_M) \times \text{k-value (per inch) of listed material } (k_L)}{.84}$  x Specified min. thickness of listed material ( $T_L$ )

$$T_M \text{ (inches)} = \frac{k_M}{*.84} \times T_L$$

$$T_M \text{ (inches)} = \frac{*.35}{*.84} \times 1"$$

$$.416 \text{ (inches)} = .416 \times 1"$$

**Answer - The minimum required thickness of the Micore 160 is .417", therefore round up to nearest standard thickness available which is 1/2".**

**Using the r formula:**

Minimum thickness of alternate material =  $\frac{\text{r-value (per Inch) of listed material } (r_L) \times \text{r-value (per inch) of alternate material } (r_M)}{.84}$  x Specified min. thickness of listed material

$$T_M \text{ (inches)} = \frac{r_L}{r_M} \times T_L$$

$$T_M \text{ (inches)} = \frac{*1.19}{*2.86} \times 1"$$

$$.416 \text{ (inches)} = .416 \times 1"$$

**Answer - The minimum required thickness of the Micore 160 is .417", therefore round up to nearest standard thickness available which is 1/2".**

Listed Material			
	k (per inch)	r (per inch)	Listed Min. Thickness
Listed Material	.84 $k_L$	1.19 $r_L$	1" $T_L$
** Approved Alternate Materials for Floor/Hearth Protection			
Alternative Materials	Thermal Values		Minimum Thickness (rounded to nearest 1/8 inch)
	k (per inch) $k_M$	r (per inch) $r_M$	Min. Thickness $T_M$
Kaowool M Board	.47	2.13	.56" (1/2")
Micore 160™ U.S. Gypsum	.35	2.86	.42" (3/8")
Micore 300™ U.S. Gypsum	.46	2.17	.55" (1/2")
Durock™ Cement Board U.S. Gypsum	1.92	.52	2.29" (2-1/4")
Hardibacker™	1.95	.513	2.32" (2-3/8")
Hardibacker 500™	2.30	.435	2.74" (2-3/4")
Cultured Stone Hearth-stone™	2.82	.355	3.36" (3-3/8")
Wonderboard	3.23	.31	3.85" (3-7/8")
Super Firetemp M Johns-Manville	.61	1.64	.73" (3/4")
Super Firetemp L Johns-Manville	.54	1.85	.64" (5/8")
Face brick	9.00	.111	10.71" (10-3/4")
Common brick	5.00	.20	5.95" (6")
Cement mortar	5.00	.20	5.95" (6")
Ceramic tile	12.5	.08	14.88" (14-7/8")
Marble	~11	~.09	13.10" (13-1/8")

**Table 1**

**\*\* If the hearth extension material(s) that is intended to be used is NOT listed on Table 1, the material can still be used if the material(s) is noncombustible. However, the manufacturer of the material must provide either the listed k-value per inch or r-value per inch with listed thickness so that the minimum thickness required for the hearth can be calculated (per instructions on this Page and/or as specified in the NFI Certification manuals).**

**Note: Also see NFI (National Fireplace Institute) Certification Manuals showing other acceptable calculation methods and acceptable alternate materials which can be used.**

**Note:** Any noncombustible material whose *k* value is less than .84 or whose *r* value is more than 1.19 is acceptable.

If the fireplace is installed on a combustible floor, use the metal safety strips (provided) on the floor extending half under the fireplace and half under the hearth extension (refer to **Figures 6 & 7**).

A wall shield is required where a continuous perpendicular side wall is within 12" of the fireplace opening (**Figure 46**). Use a 36" W x 36" H wall shield constructed of a durable, noncombustible material having an equal or better (lower *k* value) insulating value than *k* = .54 BTU IN/FT<sup>2</sup> HR °F. At no time may a perpendicular side wall be located closer than 9" from the fireplace opening.

If fireplace is installed diagonally across a 90° corner; no wall shields are required.

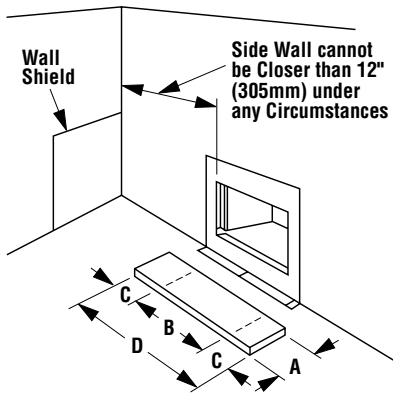

**Figure 46**

### Calculating Minimum Thickness if Multiple Materials are Used

At times it is important to know what combination of materials are acceptable for use as floor protection. The "R values" are used to determine acceptable combinations of materials because "R values" are additive where *r* and *k* values are not.

"R value" = 1/*k* = "*r*" x thickness of material used

**Example:** Given that the required "R value" for a suitable floor protector used must be equal to or greater than:

$$"R" = r_L \times T_L = 1.19 \times 1" = 1.19."$$

If it is desired to elevate a marble hearth extension to a level of 5" or more above the floor surface. What combination of noncombustible materials can be used to accomplish this?

If common brick is used so that the 3 1/2" dimension is the height, "R" for the common brick becomes:

$$\text{brick} \\ "R"_{M} = r_{M} \times T_{S} = 0.20 \times 3 \frac{1}{2}" = .70$$

Using 1/2" of mortar to set the brick, "R" for the mortar is calculated as follows:

$$\text{mortar} \\ "R"_{M} = r_{M} \times T_{S} = 0.20 \times \frac{1}{2}" = .10$$

Next, a 3/4" marble slab set in 1/2" mortar covers the brick, "R" for the marble and mortar becomes:

$$\text{marble} \\ "R"_{M} = r_{M} \times T_{S} = 0.05 \times \frac{3}{4}" = .038$$

$$\text{mortar} \\ "R"_{M} = r_{M} \times T_{S} = 0.20 \times \frac{1}{2}" = .10$$

The sum of all "R values" is: .70 + .10 + .038 + .10 = .938

This would NOT be an acceptable combination of material for the hearth extension since the total calculated "R value" of the materials used is under the required "R value" of 1.19. An additional layer of insulating materials must be used.

**Note:** Also see NFI Certification Manuals for expanded explanation on calculating "R values" when multiple materials are used.

**WARNING: THE CRACK BETWEEN THE FIREPLACE AND THE HEARTH EXTENSION MUST BE SEALED WITH A NON-COMBUSTIBLE MATERIAL.**

**WARNING: WHEN INSTALLING HEARTH EXTENSION IN FRONT, THE FIREPLACE MUST BE RAISED IF HEIGHT OF HEARTH EXTENSION EXCEEDS 7 3/4" (197MM) (LBR MODELS) ABOVE THE BOTTOM OF FIREPLACE (FIGURE 47).**

**WARNING: THE FIREPLACE MUST BE RAISED IF THE HEIGHT OF THE HEARTH EXTENSION EXCEEDS 1-1/2" (38 MM) (LBC MODELS) ABOVE THE BOTTOM OF THE FIREPLACE (FIGURE 48).**

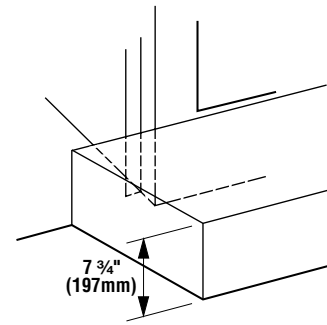

**Max. Thickness of Hearth Extension when LBR Models are on the Floor**

**Figure 47**

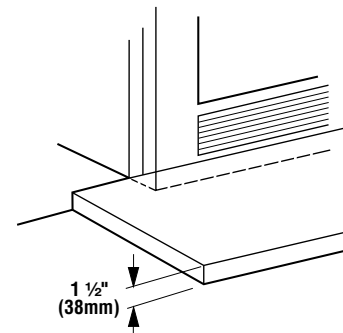

**Max. Thickness of Hearth Extension when LBC Models are on the Floor**

**Figure 48**

Secure the hearth extension to the floor to prevent possible shifting.

### FINISH TO YOUR TASTE

There are a wide variety of "finished looks" for these fireplaces, from formal wall decor with elaborate mantels to rustic wood paneling or warm brick facings.

Only noncombustible materials like stone, tile, brick, etc., may overlap the black front facing. Do not extend these materials beyond the black facing and into the firebox area. Be sure not to interfere with the installation and operation of glass doors or block the upper or lower grilles. Seal all joints between the black facing and wall surrounds to prevent air intrusion. Use non-combustible caulking material only to seal the black metal facing to the surround material on the finished wall.

Combustible materials may project beyond the sides of the fireplace opening as long as they are kept within the shaded area, as illustrated in *Figure 49* for LBR models and *Figure 50* for LBC models.

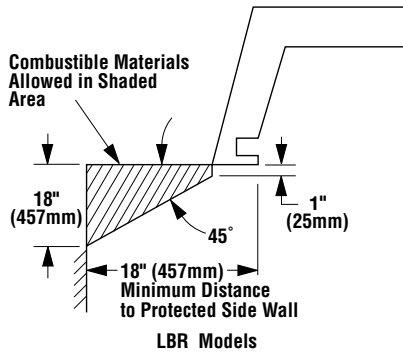

**Figure 49**

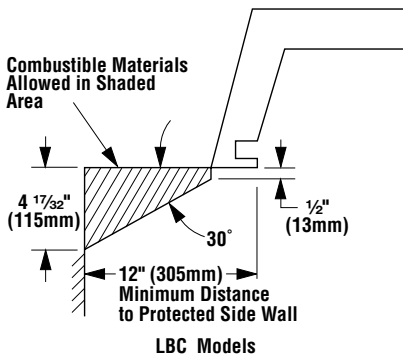
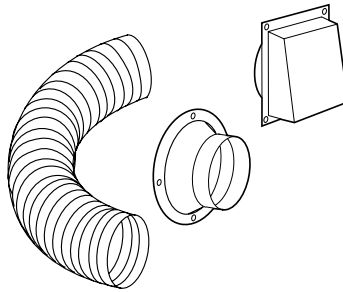

**Figure 50**

Model	Catalog Number	Weight
LBR-3824	11M70	225 lbs.
LBC-3824	11M72	225 lbs.
LBR-3824-H	11M74	225 lbs.
LBC-3824-H	11M76	225 lbs.
LBR-4324	11M71	250 lbs.
LBC-4324	11M73	250 lbs.
LBR-4324-H	11M75	250 lbs.
LBC-4324-H	11M77	250 lbs.

## INSTALLATION COMPONENTS

The following items are available for use in the installation of this appliance.



Outside Combustion Air Kits		
(with duct)	81L87	FOAK
(without duct)	81L88	FOAK-LD

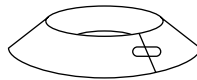

Storm Collar	63L59	FSC
--------------	-------	-----

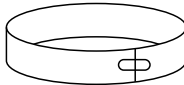

Locking Band	63L60	FLB
--------------	-------	-----

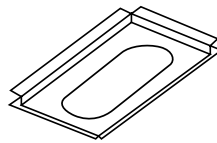

Firestop Spacer (30°)	63L37	F10FS30-2
-----------------------	-------	-----------

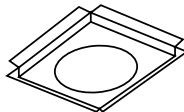

Firestop Spacer (Flat)	63L36	F10FS-2
------------------------	-------	---------



Chimney Section	63L16	FTF10-12
	63L17	FTF10-18
	63L18	FTF10-36
Canadian	62L94	FTF10-18C
Outside Chimney	62L95	FTF10-36C

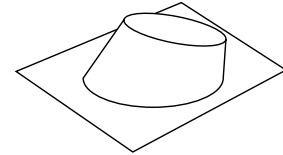

Flashing	63L40	F10F6
	63L41	F10F12

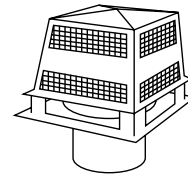

Chase Termination (Square)	63L49	FTF10-CT1
----------------------------	-------	-----------

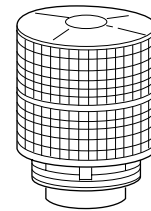

Chase Termination (Round)	63L55	FTF10-CTDTM
---------------------------	-------	-------------

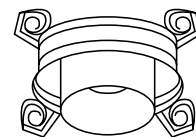

Stabilizer	63L26	FTF10-S4
------------	-------	----------

**INSTALLATION COMPONENTS  
CONTINUED**

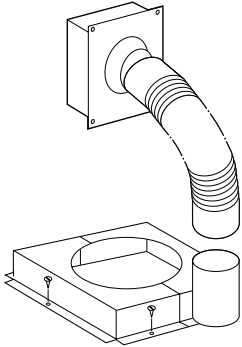

**Cold Climate Kit      63L63      FTF10-CCK1-LD**

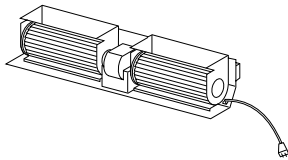

**Forced Air Kit      12M73      LFAK-2000**

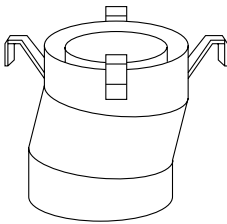

**Combination  
Offset/Return Elbow      63L34      FTF10-OR15**

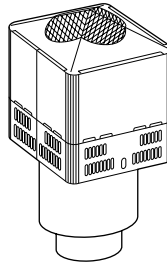

**Chase Termination      96L21      FTF10-CTT**

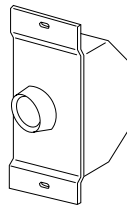

**Variable Speed  
Wall Switch      045571H      VSWS**

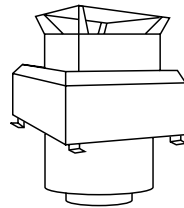

**Chase Termination  
(Square)      63L52      FTF10-CT2**

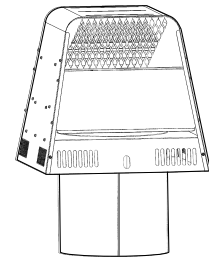

**Arch Type Termination      96L23      FTF10-ATT**

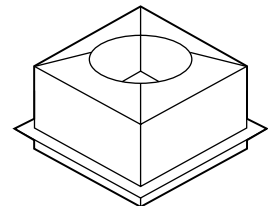

**Firestop Attic Shield  
(Canada Only)      63L68      FTF10-FSAS**

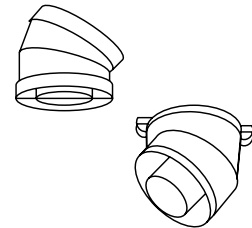

**Offset/ Return  
Package (30°)      63L23      FTF10-ES30**

NOTE: DIAGRAMS & ILLUSTRATIONS NOT TO SCALE.

Lennox Hearth Products reserves the right to make changes at any time, without notice, in design, materials, specifications, prices and also to discontinue colors, styles and products. Consult your local distributor for fireplace code information.



**HEARTH PRODUCTS**

1110 West Taft Avenue  
Orange, CA 92865