



HEARTH PRODUCTS

GAS APPLIANCE
KITS AND ACCESSORIES

750,018M
REV. E 08/2009

GAS CONVERSION KIT (FGCK)

WARNING: THIS CONVERSION KIT SHALL BE INSTALLED BY A QUALIFIED SERVICE AGENCY IN ACCORDANCE WITH THE MANUFACTURER'S INSTRUCTIONS AND ALL APPLICABLE CODES AND REQUIREMENTS OF THE AUTHORIZED AGENCY HAVING JURISDICTION. IF THE INFORMATION IN THESE INSTRUCTIONS ARE NOT FOLLOWED EXACTLY, A FIRE, EXPLOSION OR PRODUCTION OF CARBON MONOXIDE MAY RESULT CAUSING PROPERTY DAMAGE, PERSONAL INJURY OR LOSS OF LIFE. THE INSTALLATION IS NOT PROPER AND COMPLETE UNTIL THE OPERATION OF THE CONVERTED APPLIANCE IS CHECKED AS SPECIFIED IN THE OWNER INSTRUCTIONS SUPPLIED WITH THE KIT.

AVERTISSEMENT: CET ÉQUIPEMENT DE CONVERSION SERA INSTALLÉ PAR UNE AGENCE QUALIFIÉE DE SERVICE CONFORMÉMENT AUX INSTRUCTIONS DU FABRICANT ET TOUTES EXIGENCES ET CODES APPLICABLES DE L'AUTORISÉS AVOIR LA JURIDICTION. SI L'INFORMATION DANS CETTE INSTRUCTION N'EST PAS SUIVIE EXACTEMENT, UN FEU, EXPLOSION OU PRODUCTION DE PROTOXYDE DE CARBONE PEUT RÉSULTER LE DOMMAGES CAUSER DE PROPRIÉTÉ, PERTE OU BLESSURE PERSONNELLE DE VIE. L'AGENCE QUALIFIÉE DE SERVICE EST ESPONSABLE DE L'INSTALLATION PROPRE DE CET ÉQUIPEMENT. L'INSTALLATION N'EST PAS PROPRE ET COMPLÈTE JUSQU'À L'OPÉRATION DE L'APPAREIL CONVERTI EST CHÉQUE SUIVANT LES CRITÈRES ÉTABLIS DANS LES INSTRUCTIONS DE PROPRIÉTAIRE PROVISIONNÉES AVEC L'ÉQUIPEMENT.

In Canada

THE CONVERSION SHALL BE CARRIED OUT IN ACCORDANCE WITH THE REQUIREMENTS OF THE PROVINCIAL AUTHORITIES HAVING JURISDICTION AND IN ACCORDANCE WITH THE REQUIREMENTS OF THE CAN1-B149.1 AND .2 INSTALLATION CODE.

LA CONVERSION DEVRA ÊTRE EFFECTUÉE CONFORMÉMENT AUX RECOMMANDATIONS DES AUTORITÉS PROVINCIALES AYANT JURIDICTION ET CONFORMÉMENT AUX EXIGENCES DU CODE D'INSTALLATION CAN1-B149.1 ET.2.

This Gas Conversion Kit contains all of the necessary components needed to complete the conversion of an appliance from the use of one type of gas to the use of another, including labeling that must be affixed to ensure safe operation.

ALWAYS REFER TO THE APPLIANCE INSTALLATION AND HOMEOWNERS CARE AND OPERATION DOCUMENTS BEFORE COMPLETING A CONVERSION. ALL WARNINGS, CAUTIONS AND DETAILED INSTRUCTIONS CONTAINED THEREIN ARE APPLICABLE TO THIS DOCUMENT.

Note: For detailed information on derating at altitudes above 2,000 feet, please refer to the "Orifice Sizes - Sea Level To High Altitude (All Models)" section of the appliance Installation Instructions.

To complete the conversion proceed as follows:

Note: After converting the valve and gas components, refer to the appliance Installation Instructions and Care and Operation Instructions to adjust the air shutter opening for the gas type used.

CAUTION: The gas supply shall be shut off prior to disconnecting the electrical power, before proceeding with the conversion.

Step 1. Turn off the gas supply to the appliance. Remove the front glass door/frame (if used) from the appliance. Access the control compartment.

Step 2. Carefully remove the logs. Exercise care as not to break the logs.

Step 3. Locate the screws securing the burner (tray) to the appliance. Remove the burner and retain the securing screws.

Kit Components:

Electronic Valve	Size/Part No.
Burner Orifice	Refer To Appliance Installation Manual
Pilot Orifice	Refer To Appliance Installation Manual
Adjusting Screw	Provided With Kit
Slotted Cap	Provided With Kit
Spring	Provided With Kit
Labels	Provided With Kit

Millivolt Valve	Size/Part No.
Burner Orifice	Refer To Appliance Installation Manual
Pilot Orifice	Refer To Appliance Installation Manual
Valve Head	Provided With Kit
Labels	Provided With Kit

Millivolt Appliances

Step 4. SIT Systems - Refer to **Figure 1**. Using a Torx T20, or a flat screwdriver, remove and discard the three pressure regulator mounting screws. Remove the pressure regulator, spring, poppet, diaphragm and bushing.

Discard all removed components. Ensure the rubber gasket installed on the back of the replacement pressure regulator is properly positioned and install the new pressure regulator using the new screws supplied with this kit. Tighten screws to 25 In. lb. torque.

SIT VALVE

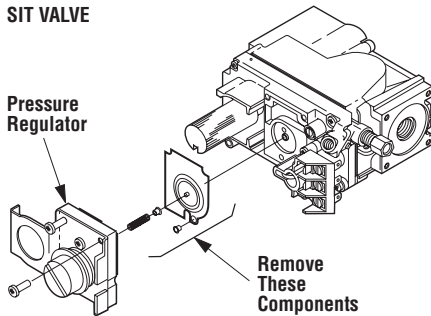

Figure 1

Step 5. Honeywell Systems - See **Figure 2**. Remove the black thread-protecting cap. Remove the conversion flip cap by turning it counterclockwise. Invert the flip cap so that the letters associated with the desired gas type are positioned closest to the valve body.

NG is for natural gas and LP is for propane. Tighten the flip cap by turning it clockwise. Replace the black thread-protecting cap.

HONEYWELL VALVE

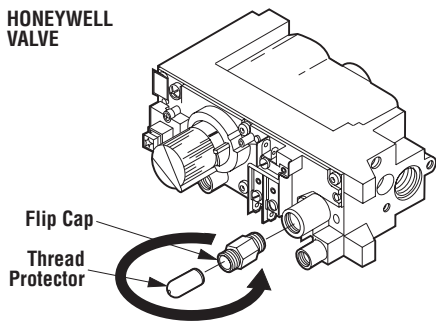

Figure 2

Step 6. Refer to **Figure 3** and remove the pilot hood assembly to access the hexed pilot orifice. Using a (4mm) Allen wrench, remove and replace the orifice with the one provided with this kit. **Figure 4** shows the pilot reassembled, with proper flame. **Figure 5** shows a typical pilot to burner relationship.

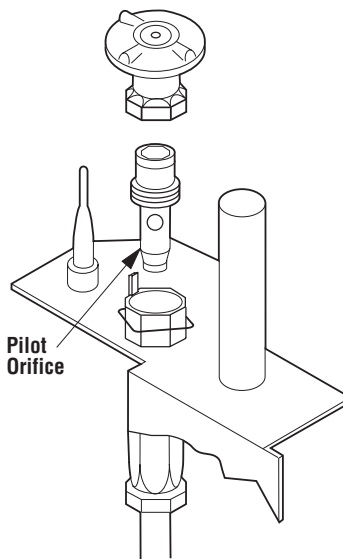

Figure 3

Electronic Appliances

Step 7. Honeywell Electronic Valves - See **Figure 7**. Remove the slotted cap screw, o-ring, pressure-regulating adjusting screw and spring. Retain all parts for possible later use. Install new components from this kit. Black cap and red spring for propane gas units. Silver cap and stainless steel spring for natural gas units.

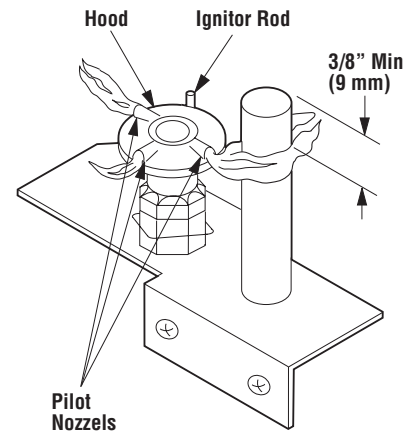
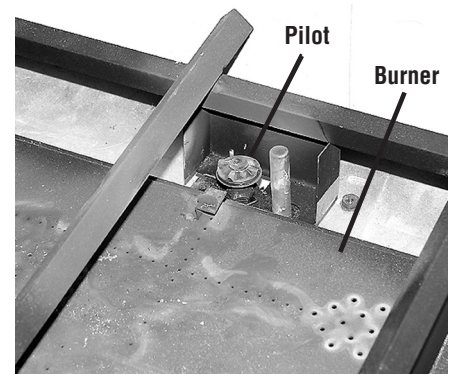

Figure 4



(Millivolt LMBV 36 Shown)

Figure 5

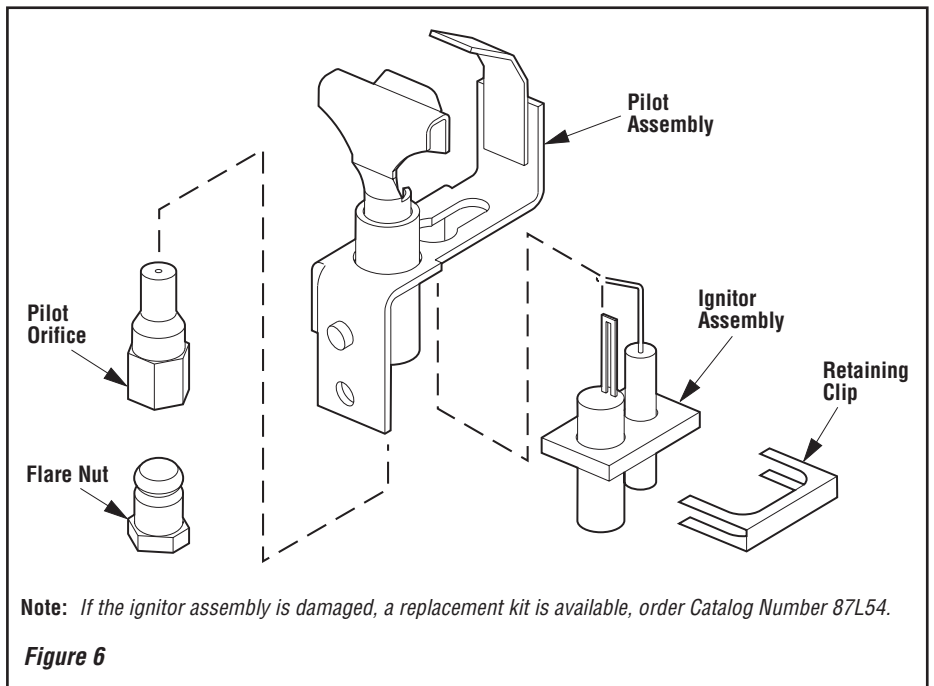

Figure 6

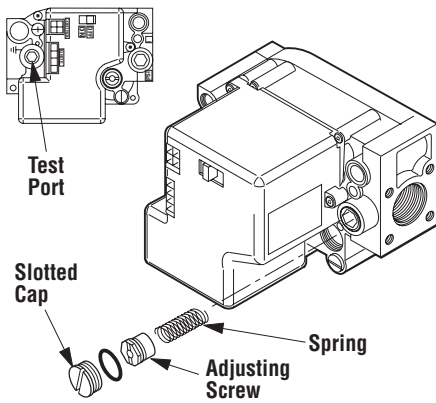

Figure 7

Step 8. Refer to **Figure 6** and replace the pilot orifice as follows: Remove the ignitor assembly retainer clip, and carefully remove the ignitor assembly. **Exercise extreme care to prevent damage to or breakage of the ignitor assembly.** Remove the screw securing the pilot assembly to its mounting bracket. Back off the flare nut at the end of the pilot gas line to free the pilot assembly from the gas line.

Remove the pilot orifice and replace it with the one provided with this conversion kit. Reinstall the pilot assembly by reversing the steps detailed here.

When reinstalling the ignitor assembly, use extreme care to prevent damage and breakage. Do not apply any leverage to the ignitor assembly while restoring the retainer clip to its original position.

ALL FIXED SETTING SIT VALVES

Millivolt Appliances

Step 9. SIT Systems - Refer to **Figure 1**. Using a Torx T20, or a flat screwdriver, remove and discard the three pressure regulator mounting screws. Remove the pressure regulator, spring, poppet, diaphragm and bushing.

Discard all removed components. Ensure the rubber gasket installed on the back of the replacement pressure regulator is properly positioned and install the new pressure regulator using the new screws supplied with this kit. Tighten screws to 25 In. lb. torque.

Step 10. Refer to **Figure 3** and remove the pilot hood assembly to access the hexed pilot orifice. Using a (4mm) Allen wrench, remove and replace the orifice with the one provided with this kit. **Figure 4** shows the pilot reassembled, with proper flame. **Figure 5** shows a typical pilot to burner relationship.

Electronic Appliances

Step 11. SIT Systems - See **Figure 8**. Using a Torx T20, or a flat screwdriver, remove and discard the three pressure regulator mounting screws. Remove the pressure regulator, spring, poppet, diaphragm and bushing. Discard all removed components.

Using a standard tin snip cutting tool, proceed to trim shoulder off of the regulator provided with the kit. Ensure the rubber gasket installed on the back of the replacement pressure regulator is properly positioned and install the new modified pressure regulator using the new screws supplied with this kit. Tighten screws to 25 In. lb. torque.

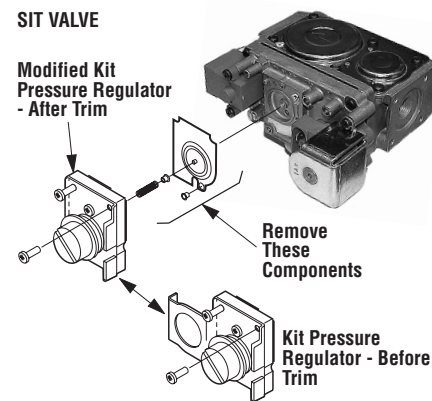

Figure 8

Step 12. Refer to **Figure 6** and replace the pilot orifice as follows: Remove the ignitor assembly retainer clip, and carefully remove the ignitor assembly. **Exercise extreme care to prevent damage to or breakage of the ignitor assembly.** Remove the screw securing the pilot assembly to its mounting bracket. Back off the flare nut at the end of the pilot gas line to free the pilot assembly from the gas line.

Remove the pilot orifice and replace it with the one provided with this conversion kit. Reinstall the pilot assembly by reversing the steps detailed here.

When reinstalling the ignitor assembly, use extreme care to prevent damage and breakage. Do not apply any leverage to the ignitor assembly while restoring the retainer clip to its original position.

All Models

Step 13. Unscrew the orifice from the manifold and replace it with the one provided with this kit (**Figure 9**).

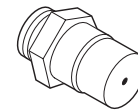

Figure 9

Step 14. Reassemble all removed components by reversing the procedures outlined in the preceding steps. Use pipe joint compound or Teflon tape on all pipe fittings before installing (ensure propane resistant compounds are used in propane applications, do not use pipe joint compounds on flare fittings). Adjust the air shutter opening on the burner tube, refer to **Note** on page 1.

Step 15. Attach appropriate conversion kit label (**Figure 10**) next to the rating plate on the appliance. Attach the installer conversion label next to the gas valve, after filling out the information on the label. Refer to the Installation Instructions for required input rating.

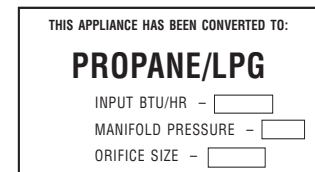
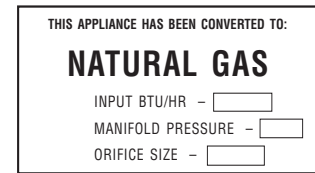

Figure 10

Step 16. Turn on gas supply and test for gas leaks, using a gas leak test solution (also referred to as bubble leak solution).

Step 17. Attach manometer to the manifold side pressure test fitting (1/4" Allen wrench for Electric units) and adjust screw until pressure reads 3.5 inches water column (6.54 MmHg) for natural gas, and 10.0 inches water column (18.69 MmHg) for propane gas. Refer to the Installation Instructions and the Table below.

Inlet Gas Supply Pressure		
Fuel #	Minimum	Maximum
Propane	11.0" WC (2.74 kPa)	13.0" WC (3.23 kPa)
Natural	4.5" WC (1.24 kPa)	10.5" WC (2.61 kPa)

Step 18. For detailed Lighting Instructions, refer to the Care And Operations instructions.

Lennox Hearth Products reserves the right to make changes at any time, without notice, in design, materials, specifications, prices and also to discontinue colors, styles and products. Consult your local distributor for fireplace code information.



HEARTH PRODUCTS

Printed in U.S.A. © 2000 by Lennox Hearth Products

P/N 750,018M REV. E 08/2009

1110 West Taft Avenue • Orange, CA 92865