

INSTALLATION INSTRUCTIONS FOR THE SYMMETRY AND SPECTRA SERIES GAS CONVERSION KITS

WARNING: THIS CONVERSION KIT SHALL BE INSTALLED BY A QUALIFIED SERVICE AGENCY IN ACCORDANCE WITH THE MANUFACTURER'S INSTRUCTIONS AND ALL APPLICABLE CODES AND REQUIREMENTS OF THE AUTHORIZED HAVING JURISDICTION. IF THE INFORMATION IN THESE INSTRUCTIONS IS NOT FOLLOWED EXACTLY, A FIRE, EXPLOSION OR PRODUCTION OF CARBON MONOXIDE MAY RESULT CAUSING PROPERTY DAMAGE, PERSONAL INJURY OR LOSS OF LIFE. THE INSTALLATION IS NOT PROPER AND COMPLETE UNTIL THE OPERATION OF THE CONVERTED APPLIANCE IS CHECKED AS SPECIFIED IN THE OWNER INSTRUCTIONS SUPPLIED WITH THE KIT. THE QUALIFIED SERVICE AGENCY PERFORMING THIS INSTALLATION ASSUMES RESPONSIBILITY FOR THIS CONVERSION.

AVERTISSEMENT: CET ÉQUIPEMENT DE CONVERSION SERA INSTALLÉ PAR UNE AGENCE QUALIFIÉE DE SERVICE CONFORMÉMENT AUX INSTRUCTIONS DU FABRICANT ET TOUTES EXIGENCES ET CODES APPLICABLES DE L'AUTORISÉS AVOIR LA JURIDICTION. SI L'INFORMATION DANS CETTE INSTRUCTION N'EST PAS SUIVIE EXACTEMENT, UN FEU, EXPLOSION OU PRODUCTION DE PROTOXYDE DE CARBONE PEUT RÉSULTER LE DOMMAGES CAUSER DE PROPRIÉTÉ, PERTE OU BLESSURE PERSONNELLE DE VIE. L'AGENCE QUALIFIÉE DE SERVICE EST ESPONSABLE DE L'INSTALLATION PROPRE DE CET ÉQUIPEMENT. L'INSTALLATION N'EST PAS PROPRE ET COMPLÈTE JUSQU'À L'OPÉRATION DE L'APPAREIL CONVERTI EST CHÉQUE SUIVANT LES CRITÈRES ÉTABLIS DANS LES INSTRUCTIONS DE PROPRIÉTAIRE PROVISIONNÉES AVEC L'ÉQUIPEMENT.

In Canada:

THE CONVERSION SHALL BE CARRIED OUT IN ACCORDANCE WITH THE REQUIREMENTS OF THE PROVINCIAL AUTHORITIES HAVING JURISDICTION AND IN ACCORDANCE WITH THE REQUIREMENTS OF THE CAN1-B149.1 AND .2 INSTALLATION CODE.

LA CONVERSION DEVRA ÊTRE EFFECTUÉE CONFORMÉMENT AUX RECOMMANDATIONS DES AUTORITÉS PROVINCIALES AYANT JURIDICTION ET CONFORMÉMENT AUX EXIGENCES DU CODE D'INSTALLATION CAN1-B149.1 ET.2.

Gas conversion kits are available to adapt your appliance from the use of one type of gas to the use of another. These kits contain all the necessary components needed to complete the task including labeling that must be affixed to ensure safe operation.

Kit part numbers are listed here and the following steps detail the conversion procedure.

Step 1. Turn off the gas supply to the appliance.

Step 2. Carefully remove the logs. Exercise care so as not to break the logs.

Step 3. See *Figures 1 and 2*. Remove the burner assembly with attached venturi tube.

Electronic Appliances

Step 4. SIT Systems - Refer to *Figure 5* and the instructions provided with the kit. **Discard all removed components.**

Step 5. Shut off the gas supply to the valve and shut down the electric supply.

Step 6. See *Figure 5*. Using a Torx T20, or slotted screwdriver, remove and discard the two (2) pressure regulator mounting screws, pressure regulator tower, the diaphragm assembly (A) (if applicable) and the spring (B).

Step 7. Ensure the rubber gasket (C), which is pre-fitted as part of the assembly, is properly positioned (see *Figure 5*).

Natural To Propane Gas Conversion Kits	
Models	Catalog No.
SYM-35	H7749
SYM-40	H7750
SYM-45	H7751

Propane To Natural Gas Conversion Kit	
Models	Catalog No.
SYM-35	H7752
SYM-40	H7753
SYM-45	H7754

Natural To Propane Gas Conversion Kits	
Models	Catalog No.
LSS-35	H7852
LSS-40	H7853

Propane To Natural Gas Conversion Kit	
Models	Catalog No.
LSS-35	H7854
LSS-40	H7855

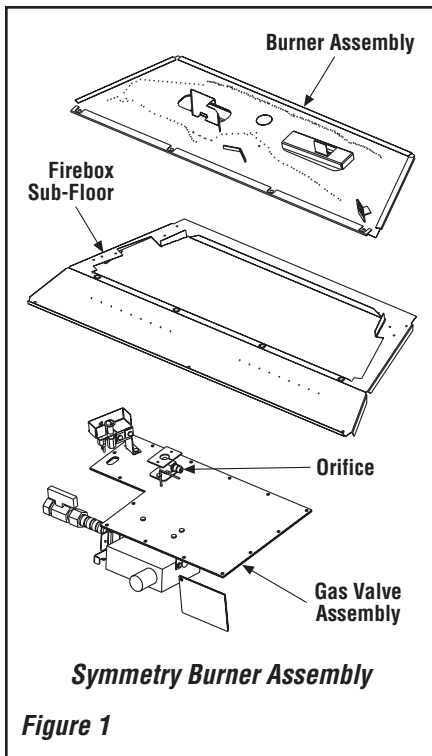

Figure 1

Step 8. Install the new Stepper Motor pressure regulator assembly using the supplied screws as shown in **Figure 5**. Tighten screws securely (reference torque = 25 lb. in.).

Step 9. Install the enclosed identification label to the valve body where it can be easily seen.

Step 10. Make Stepper Motor and valve electrical connections.

Step 11. Attach manometer to the manifold side pressure test fitting and verify manifold pressure reads 3.5 inches water column (0.87 kPa) for natural gas, and 10.0 inches water column (2.49 kPa) for propane gas (see **Figure 5**).

Step 12. See **Figure 6** and replace the pilot orifice as follows: Remove the pilot hood assembly to access the hexed pilot orifice. Remove and replace the orifice with the one provided with the kit. **Exercise extreme care to prevent damage to or breakage of the ignitor assembly.**

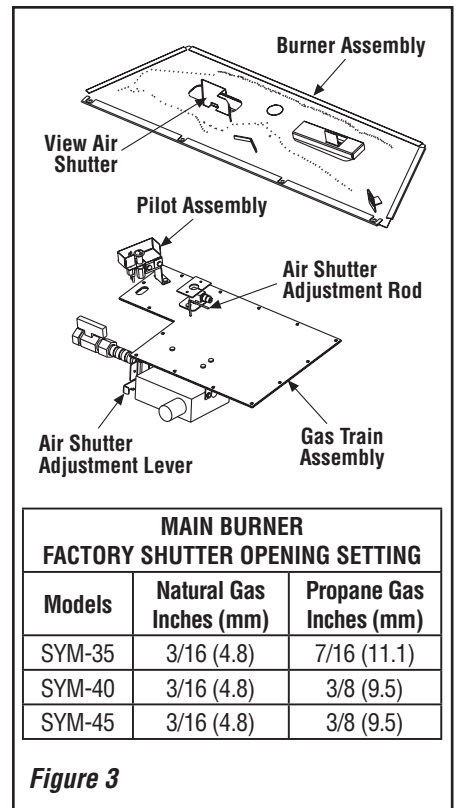

Figure 3

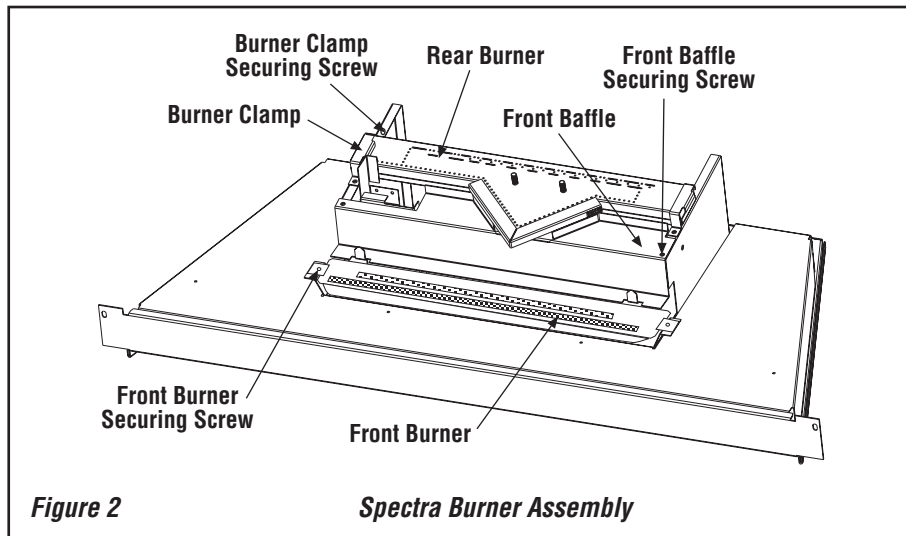

Figure 2

Spectra Burner Assembly

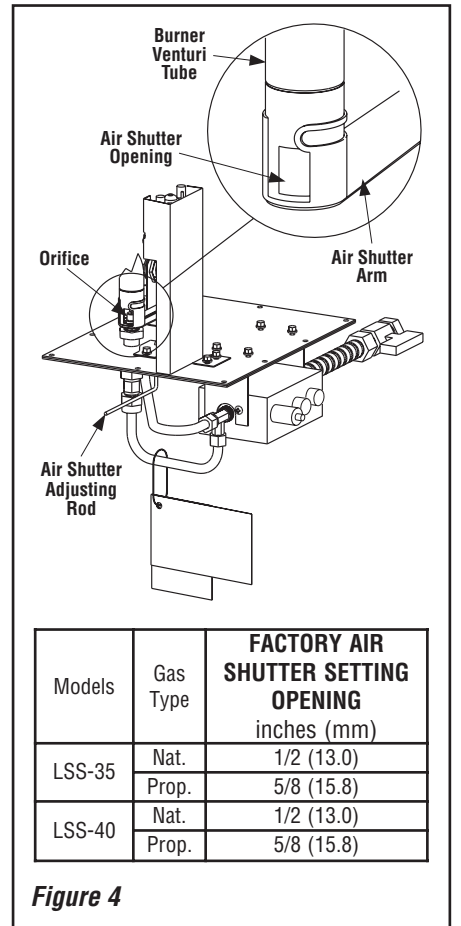

Figure 4

Step 13. (Refer to *Figures 1 and 2*)

Remove the orifice from the manifold and replace it with the one provided in the kit. See the following Orifice Tables for orifice sizes for natural and propane models. *Figure 7* illustrates the orifice.

Step 14. Reassemble the remaining components by reversing the procedures outlined in the preceding steps. Use pipe joint compound or Teflon tape on all pipe fittings before installing (ensure propane resistant compounds are used in propane applications, do not use pipe joint compounds on flare fittings).

Retrieve the burner and slide the venturi tube over the orifice. Set the shutter adjusting opening as shown in *Figures 3 and 4*.

Step 15. Attach the conversion label provided in the conversion kit to the rating plate on the appliance.

Step 16. Apply gas to the system and relight appliance. With the main burner "ON", test the new pressure regulator assembly for leaks using a leak test solution.

Step 17. Relight the main burner and verify proper burner ignition and operation.

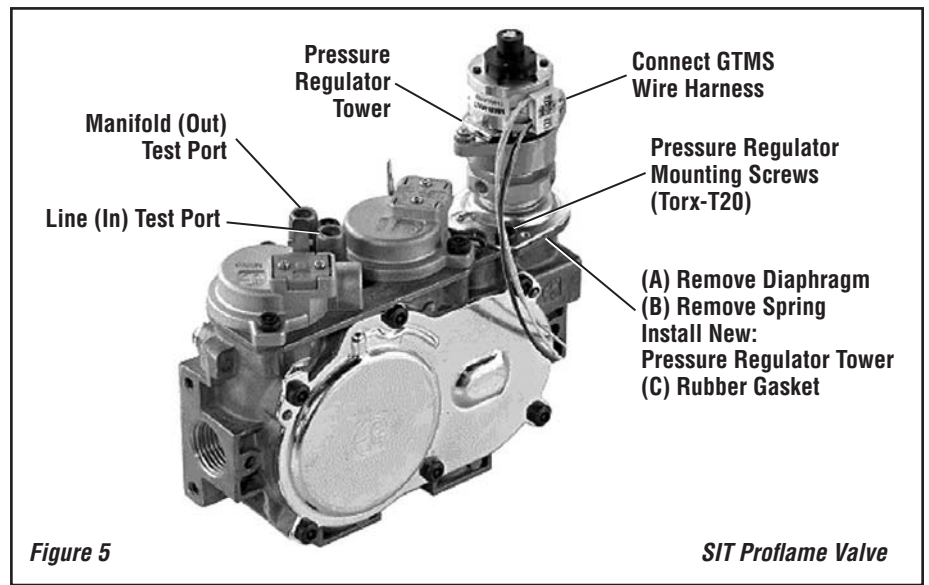

Figure 5

SIT Proflame Valve

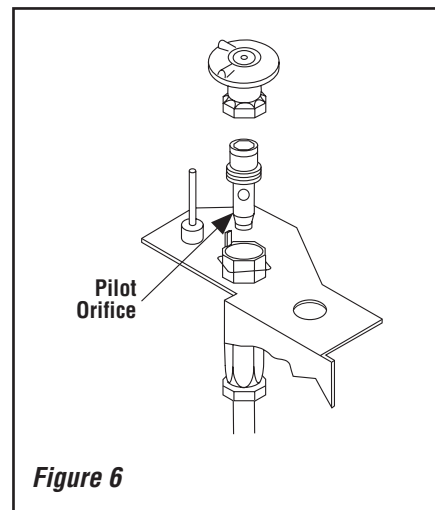

Figure 6

Models	Orifice Size	
	Nat.	Prop.
SYM-35	#35	0.062"
SYM-40	#32	0.065"
SYM-45	0.119"	0.068"

Model	Fuel	Rear Burner	Front Burner
LSS-35CN	Nat. Gas	#44	#50
LSS-35CP	LP Gas	#55	#61
LSS-40CN	Nat. Gas	#42	#45
LSS-40CP	LP Gas	0.054"	#56

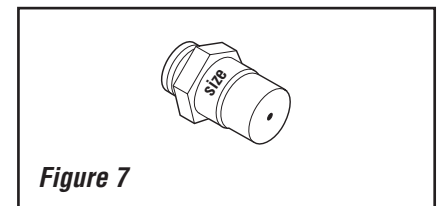

Figure 7

Lennox reserves the right to make changes at any time, without notice, in design, materials, specifications, prices and also to discontinue colors, styles and products.
Consult your local distributor for fireplace code information.



HEARTH PRODUCTS

1110 West Taft Avenue • Orange, CA 92865

Printed in U.S.A. © 2009 Lennox Hearth Products
P/N 506019-44 REV. A 08/2009