



Combining advanced wood-burning technology and dramatic aesthetics, this highly efficient, EPA-certified fireplace delivers optimal heat and modern refinement in one outstanding showpiece.

LENNOX
HEARTH PRODUCTS



DAVE LENNOX
signature
COLLECTION

The Dave Lennox *Signature™* Collection Ladera™ high-efficiency wood-burning fireplace is a contemporary marvel. Advanced features, like a Double-Air Combustion control, allow you to enjoy a continuous fire without the need for reignites and it helps optimize efficiency. A compact, yet open firebox accepts logs up to 18 inches for large flames, long burn times and additional warmth. And with a clean-face design and expansive viewing area, this EPA-certified fireplace allows you to take pleasure in the modern beauty of an unobstructed fire with a true masonry fireplace feel.



Ladera™ shown with black door

Brushed nickel door

DIMENSIONS

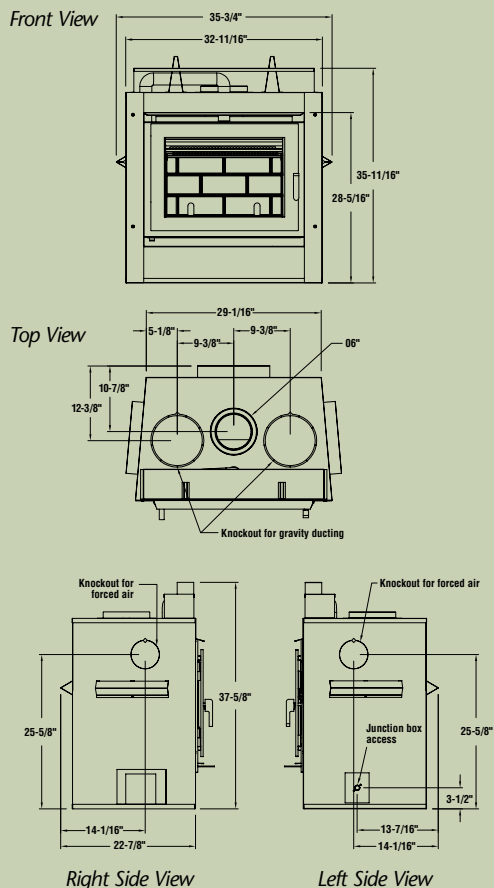

STANDARD FEATURES

- EPA-certified
- Heats up to 50,000 BTUs and up to 1,500 sq. ft.*
- Louverless installation focuses on the beauty of the fire and mimics the look of a masonry fireplace
- Zero clearance to combustibles
- Airtight combustion chamber delivers maximum efficiency
- Available with choice of black or brushed nickel door
- Convenient factory-installed fan for added value
- All-in-one Double-Air Combustion control includes air boost for faster wood ignition and main air control for variable heat output
- Efficient air wash system keeps glass clean
- Firebox accepts up to 18" logs for greater heat output and longer burn times
- Ceramic glass for added safety and optimum heat transfer
- Expansive glass area allows for unobstructed views of the fire
- Textured refractory-lined firebox recreates a traditional masonry appearance
- 20-year limited warranty

*Square-foot heating capacities and burn times are approximations only. Actual performance may vary depending upon home design and insulation, ceiling heights, climate, condition and type of wood used, appliance location, burn rate, accessories chosen, chimney installation and how the appliance is operated.

**Use with Forced-Air Kit in the United States voids EPA certification.

OPTIONAL ACCESSORIES

- Cast-iron surround and optional decorative keystone
- Gravity air distribution kit
- Forced-Air Kit**
- Outside air kit
- Rigid firescreen



Cast-iron surround

Cast-iron surround with decorative keystone

ENGINEERED TO BE THE BEST—COMMON FEATURES OF LENNOX EPA-CERTIFIED FIREPLACES

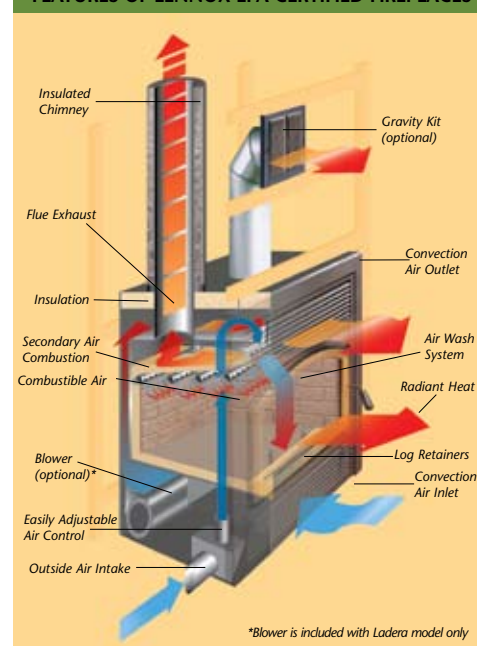

IMPORTANT NOTES:

As with any heating appliance, fireplace or stove, this appliance is extremely hot during operation. Read and understand all operating instructions before using this appliance. For further information, consult your dealer.

Diagrams, illustrations and photographs are not to scale—consult installation instructions. Product designs, materials, dimensions, specifications, colors and prices are subject to change or discontinuance without notice.



PRODUCTS YOU CAN COUNT ON

Lennox is committed to providing you with high-quality products. A qualified dealer can help you find the right product to give you years of comfort and enjoyment.



HEARTH PRODUCTS

© Lennox Industries Inc. 2009

Visit us at www.lennox.com, or contact us at 1-800-9-LENNOX.